

Robin Z5xx

Datasheet

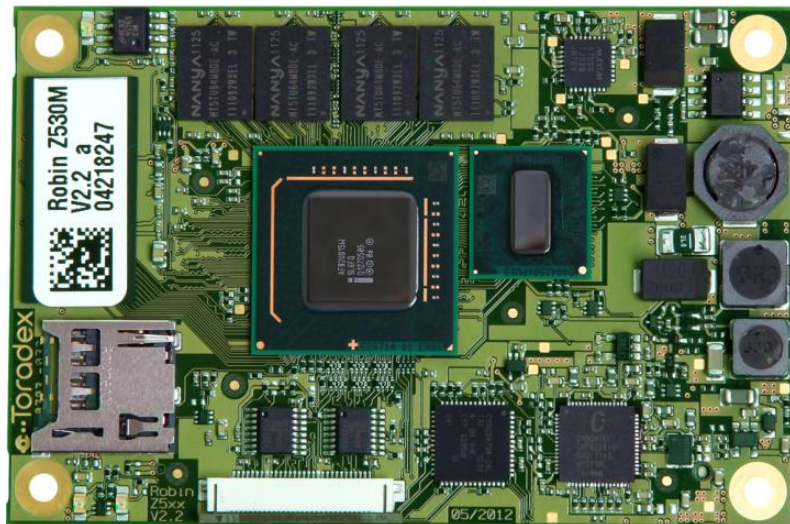

Revision History

Date	Doc. Rev.	Robin Z5xx Versions	Changes
18-Nov-09	0.1	V2.0	Preliminary Release
04-Feb-10	1.0	V2.0	chapter LPC + note for LPC_CLK grammar changes chapter AC power adaptor 5.2.1
02-Jul-10	1.1	V2.0, V1.0	New chapter 2.2. Variants New chapter: 4.9 TV out Moved chapter: 8.1. Temperature Range Moved chapter: 8.2. Notes for a custom heatsink...
13-Jul-10	1.2	V2.0, V1.0	Minor changes
16-Sept-10	1.3	V2.0, V1.0	Updated power consumption table
21-Sept-10	1.31	V2.0, V1.0	Minor correction in SDIO/GPIO chapter 3.3.1
22-Sept-10	1.32	V2.0, V1.0	Minor correction in Programming Guide to the Oak Sensor Family chapter 1.1.3
01-Feb-11	1.33	V2.0, V1.0	Update external links in chapter 1.1.4 Additional remark to power up sequence chapter 5.3 New Disclaimer
05-May-11	1.34	V2.0, V1.0	Pins B93 & B94 changed to 5V Rail

Contents

1. Introduction.....	6
1.1. Reference Documents	6
1.1.1 COM Express™ Design Guide.....	6
1.1.2 COM Express™ Reference Board Schematics.....	6
1.1.3 Programming Guide to the Oak Sensor Family	6
1.1.4 Cypress CY8C24794.....	6
1.1.5 Chrontel CH7022.....	6
2. Features	7
2.1. Block Diagram.....	7
2.2. Variants	8
2.3. CPU and Chipset	8
2.4. Interfaces.....	9
2.5. Differences between Robin V2.0 to Robin V1.0	10
2.5.1 DDR2 x8 instead of x16 DDR2.....	10
2.5.2 SDIO / GPIO switch.....	10
2.5.3 PCB thickness	10
2.5.4 FFC shifted	10
2.5.5 Thermal sensor.....	10
3. Robin Connectors	11
3.1. Physical Location	11
3.2. Signal Notation.....	11
3.2.1 Signal Types.....	11
3.2.2 Signal Voltage Rail	12
3.3. COM Express Connector Pin Assignment.....	12
3.3.1 SDIO / GPIO signals.....	17
3.4. Assignment of additional FFC Connector	18
4. Signal Description.....	19
4.1. System Memory	19
4.2. Serial ATA	19
4.3. USB Interface.....	19
4.3.1 USB mapping	19
4.3.2 USB client.....	20
4.4. Ethernet Controller	20
4.5. PCI Express	20
4.6. ExpressCard	20
4.7. SDIO, SD Card and MMC	20
4.8. VGA.....	21
4.9. TV out.....	21
4.10. Robin Z5xx Module LEDs	21
4.11. LPC	22
5. Power Supply	23
5.1. Power States.....	23
5.2. Power Supply	24
5.2.1 AC Power Adaptor.....	24

5.2.2	ATX-Like Configuration using SUS_S5# as PS_ON.....	25
5.2.3	ATX-Like Configuration using SUS_S3# as PS_ON.....	26
5.2.4	Configuration without Standby Supply	27
5.2.5	Minimum Power Configuration	28
5.3.	Power Sequences	29
5.3.1	G3 to S0 controlled by Power Button	29
5.3.2	G3 to S0 without Waiting for Power Button	30
5.3.3	S0 to S5 Shutdown.....	30
5.3.4	S0 to S3 Suspend to RAM.....	31
5.3.5	S3 to S0 Resume	31
5.3.6	Power Button Emergency Shutdown.....	32
	Wakeup Events	32
6.	Robin Embedded Controller	33
6.1.	INTERRUPT OUT Report Contents (Real time data)	33
6.1.1	GPIO Command	34
6.1.2	Watchdog.....	34
6.1.3	I ² C interface	34
6.2.	INTERRUPT IN Report Contents (Real time data)	35
6.2.1	Frame Number	35
6.2.2	GPIO Values.....	35
6.2.3	I ² C interface	35
6.2.4	System Status	35
6.3.	FEATURE Report Commands for GPIO	36
6.3.1	Report Mode	36
6.3.2	Sample Rate	36
6.3.3	GPIO Direction	36
6.3.4	GPIO Output Mode.....	37
6.3.5	Standby Configuration	37
6.4.	FEATURE Report Commands for Watchdog.....	37
6.4.1	Watchdog mode	37
6.4.2	Strobe Interval	38
6.4.3	Watchdog Enable Delay	38
6.4.4	Watchdog Source	38
6.4.5	Service Watchdog	39
6.4.6	Reset Watchdog Pin.....	39
6.5.	FEATURE Report Commands for Power Management	39
6.5.1	Boot Mode	39
6.5.2	S3 Signalization Mode.....	39
6.5.3	Reset THRM Pin.....	40
6.6.	Toradex Z5xx Tweaker Tool	40
7.	Watchdog	41
8.	Thermal considerations.....	43
8.1.	Temperature Range	43
8.2.	Notes for a custom heatsink or heatspreader	43
8.3.	Temperature sensor chip	44
8.3.1	Warning signal.....	44
8.3.2	Critical Temperature signal.....	44
8.3.3	Default BIOS values	44
9.	Technical Specification	45

9.1. Electrical Characteristics	45
9.2. Power Consumption	45
9.3. Mechanical characteristics	46
9.3.1 Mechanical characteristics of Robin Z5xx V1.0.....	46
9.3.2 Mechanical characteristics of Robin Z5xx V2.0.....	46
9.3.3 Details with height information	47
9.4. RoHS Compliance.....	47

1. Introduction

Robin Z5xx is an embedded Nano COM Express™ computer module designed for high performance computing with low power consumption. Robin Z5xx is based on the Intel® Atom™ Z530 or Z510 processors and the Intel® System Controller Hub US15W. Robin Z530 is based on the Intel® Atom™ Z530 processor running at 1.6GHz. Robin Z510 is a lower cost module based on the Intel® Atom™ Z510 processor running at 1.1GHz.

Robin Z530 offers a single PCI Express x1 lane, GLAN, HDA and up to 7 High Speed USB ports for fast signal connectivity. One USB port can be configured as USB client. In standard configuration, it features dual independent graphical outputs with VGA and LVDS.

Robin Z5xx provides various possibilities for storing data. A Solid State Drive (SSD) and a MicroSD card slot are provided on the module itself. A SATA and SDIO interface are available on the COM Express™ connector. A 30 pin FFC connector features an additional SDIO channel for SD cards, MMC cards, WLAN adaptors, Bluetooth adaptors, modems, IrDA adapters, RFID readers or GPS modules.

1.1. Reference Documents

For detailed technical information about the components of the Robin module and the COM Express™ standard, please refer to the documents listed below.

1.1.1 COM Express™ Design Guide

Guidelines for designing a COM Express™ carrier board

http://www.comexpress-pnp.org/uploads/media/COMExpressPnP_DG_09.pdf

1.1.2 COM Express™ Reference Board Schematics

Schematic diagrams of the COM Express™ evaluation carrier board

http://www.comexpress-pnp.org/uploads/media/CEVAPnP_SAO_09.pdf

1.1.3 Programming Guide to the Oak Sensor Family

Application note regarding the access of the Robin Embedded Controller (which is software compatible with the Toradex Oak Sensor Family of Toradex)

http://files.toradex.com/Oak/Oak_ProgrammingGuide.pdf

1.1.4 Cypress CY8C24794

Embedded Controller

<http://www.cypress.com/?docID=26676>

1.1.5 Chrontel CH7022

SDVO to VGA converter

<http://www.chrontel.com/pdf/7021-7022ds.pdf>

2. Features

2.1. Block Diagram

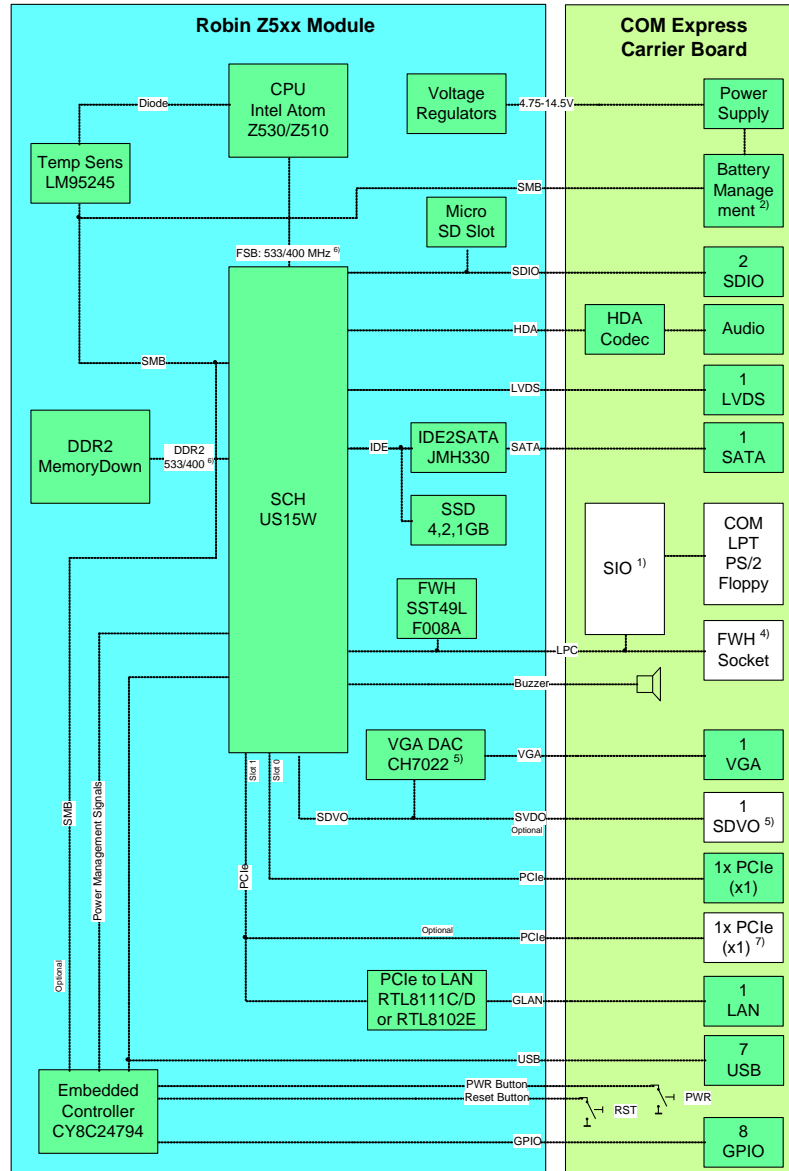

- 1) Super IO is only supported by the newest BIOS versions. Please contact Toradex for more information.
- 2) Battery Management requires the customization of the BIOS/Driver. Please contact Toradex for more information.
- 3) Assembly option for higher volumes: Realtek RTL8102E Fast Ethernet controller instead of Realtek RTL8111C/D Gigabit Ethernet controller.
- 4) Optional firmware hub (FWH) on base board. Onboard FWH can be disabled.
- 5) Assembly option for higher volumes: SDVO output instead of on Module VGA DAC.
- 6) DDR2 and FSB are 533 for Robin Z530 and 400 on Z510.
- 7) Assembly option for higher volumes: Additional PCIe instead of Ethernet controller.

2.2. Variants

From Toradex, several variants are available. Those variants differ in the assembled key components and price.

Variant	S	M	L
CPU	Z510	Z530	Z530
FSB, DDR Frequency	400MHz	533MHz	533MHz
DDR RAM	512MByte	512MByte	1GByte
Solid State Disk (SSD)	1/2GByte	2GByte	4GByte
PCB Version	V1.0	V1.0	V2.0
PCB thickness	1.6mm	1.6mm	2.0mm

2.3. CPU and Chipset

	Robin with CPU Z530	Robin with CPU Z510
Processor	Intel® Atom™ Z530	Intel® Atom™ Z510
CPU Clock	1.6 GHz	1.1 GHz
Front Side Bus	533MHz	400MHz
Instruction Cache	32kByte	32kByte
L1 Cache	24kByte	24kByte
L2 Cache	512kByte	512kByte
Hyper Thread	Yes	No
Chipset	Intel® System Controller Hub US15W	Intel® System Controller Hub US15W
Video Controller	Integrated Intel® Graphics, Intel® GMA 500, HDTV/HD capable Decoder for MPEG2(HD) /H2.64	Integrated Intel® Graphics, Intel® GMA 500, HDTV/HD capable Decoder for MPEG2(HD) /H2.64

2.4. Interfaces

Robin Z5xx V1.0 / V2.0	
PCI Express	1 PCIe x1
ExpressCard	1 Supported
Ethernet	10/100/1000 Mbit LAN ¹⁾
Audio	Intel® High Definition Audio (24bit/96kHz)
Serial ATA	1 (IDE bridge)
USB	7x USB 2.0 (1 channel configurable as client)
SD Memory Card	MicroSD slot on board
SDIO	1 on Com Express connector (4bit) 1 on separate FFC connector (8bit)
LVDS	Single Channel 18/24 bit WXGA 1366x768
SDVO	No ²⁾
Analog VGA	Yes
TV out	Yes
LPC	Yes
SMB	Yes
I ² C	Yes (over Embedded Controller)
GPIO	8 over Embedded Controller, available on -Robin V1.0 FFC -Robin V2.0 FFC or Com Express connector

Notes:

- 1) Assembly option for higher volumes: Realtek RTL8102E Fast Ethernet controller instead of Realtek RTL8111C Gigabit Ethernet controller.
- 2) Assembly option for higher volumes: SDVO output instead of Chrontel CH7022.

2.5. Differences between Robin V2.0 to Robin V1.0

By Robin V1.0 and V2.0 the PCB version is meant.

2.5.1 DDR2 x8 instead of x16 DDR2

Robin V2.0 utilizes DDR2 RAM devices with a x8 bit bus width in contrast to Robin V1.0, which utilizes DDR2 RAM devices with x16 bit bus width. This allows Robin V2.0 to provide up to 2GByte of RAM, in comparison with the maximum 1GByte of RAM available on Robin V1.0.

2.5.2 SDIO / GPIO switch

Robin V2.0 provides either a GPIO or SDIO interface on the COM Express connector. The same GPIO signals available on the FFC connector of Robin V1.0 are also available on Robin V2.0.

2.5.3 PCB thickness

The Robin V2.0 PCB has a nominal thickness of 2mm compared to 1.6mm for Robin V1.0.

This may have an impact for customers who have implemented a mechanical design that is affected by PCB thickness. To ensure compatibility between Robin V1.0 and V2.0 in such designs, Toradex will provide a dedicated Heatspreader for Robin V2.0, which will compensate for the PCB height difference.

2.5.4 FFC shifted

The FFC connector has been shifted closer to the PCB edge with respect to the front edge of the connector. Its position with respect to the adjacent PCB edge has not changed.

2.5.5 Thermal sensor

The thermal sensor has been moved away from the key heat sources (the Atom processor and US15W system control hub) to provide a more accurate measurement of the module temperature. The Atom processor temperature is still measured internally to the core.

3. Robin Connectors

3.1. Physical Location

The Robin Z530 and Z510 computer modules comply with the COM Express™ pin out type 1 for most of the signals. Only one 220 pin COM Express™ connector is available. A 30 pin FFC connector featuring an additional SDIO channel and 8 GPIOs is available. An on board MicroSD slot is also available.

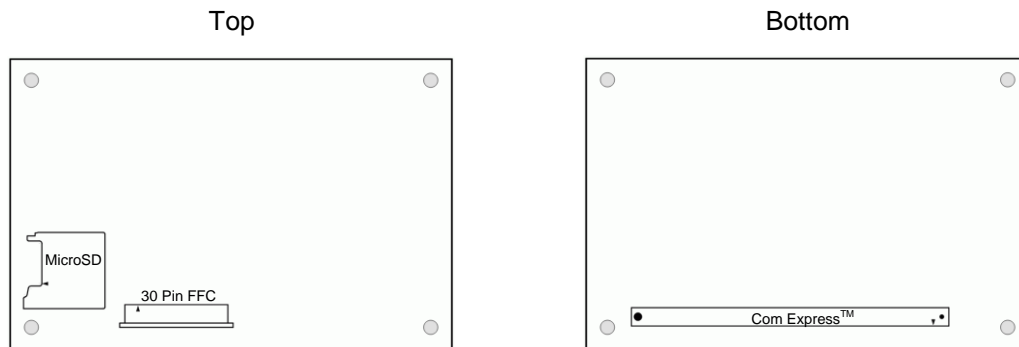

3.2. Signal Notation

3.2.1 Signal Types

Type	
I	Input to the module
O	Output from the module
IO	Bi-directional input/output signal
OD	Open drain bi-directional
ODI	Open drain input
ODO	Open drain output
NC	Not Connected
REF	Reference Signal

Note: A “#” symbol after a signal name refers to an active low signal, indicating a signal is in the active state when driven to a low level.

3.2.2 Signal Voltage Rail

Rail	
5	5V
3.3	3.3V
3.3/5	Nominal 3.3V; 5V tolerant input
2.5	2.5V
A	Analog
PWR	Power supply and ground
LVDS	Low voltage differential signaling
PCIe	PCI Express differential signaling
SATA	Serial ATA differential signaling

3.3. COM Express Connector Pin Assignment

The following pin assignment is the same for both Robin Z530 and Z510. Optional pin assignments are marked by a ¹⁾ whereas differences to the COM Express™ pin out type 1 are marked by a ²⁾.

Pin	Signal	Type	Rail	Description
A1	GND		PWR	Ground
A2	GBE0_MDI3-	IO	A	Gigabit LAN pair 3 (negative); not used for fast Ethernet
A3	GBE0_MDI3+	IO	A	Gigabit LAN pair 3 (positive); not used for fast Ethernet
A4	GBE0_LINK100#	O	3.3	LED LAN speed 100Mbps
A5	GBE0_LINK1000#	O	3.3	LED LAN speed 1Gbps
A6	GBE0_MDI2-	IO	A	Gigabit LAN pair 2 (negative); not used for fast Ethernet
A7	GBE0_MDI2+	IO	A	Gigabit LAN pair 2 (positive); not used for fast Ethernet
A8	GBE0_LINK#	O	3.3	LED LAN link indicator
A9	GBE0_MDI1-	IO	A	Gigabit LAN pair 1 (negative); fast Ethernet RX-
A10	GBE0_MDI1+	IO	A	Gigabit LAN pair 1 (positive); fast Ethernet RX+
A11	GND		PWR	Ground
A12	GBE0_MDI0-	IO	A	Gigabit LAN pair 0 (negative); fast Ethernet TX-
A13	GBE0_MDI0+	IO	A	Gigabit LAN pair 0 (positive); fast Ethernet TX+
A14	GBE0_CTREF	REF	A	Reference voltage for the magnetic center tap. Robin: not connected.
A15	SUS_S3#	O	3.3	Indicates the system is suspended to RAM
A16	SATA0_TX+	O	SATA	Serial ATA transmit channel 0 (positive)
A17	SATA0_TX-	O	SATA	Serial ATA transmit channel 0 (negative)
A18	SUS_S4#	O	3.3	Indicates the system is suspended to disk. Note: Robin does not distinguish suspend state S4 and S5
A19	SATA0_RX+	I	SATA	Serial ATA receive channel 0 (positive)
A20	SATA0_RX-	I	SATA	Serial ATA receive channel 0 (negative)
A21	GND		PWR	Ground
A22-A23	NC	NC		Not Connected
A24	SUS_S5#			Indicates the system is in SoftOff state. Can be used to control an ATX power supply. Note: Robin does not distinguish suspend states S4 and S5

Pin	Signal	Type	Rail	Description
A25-A26	NC	NC		Not Connected
A27	BATLOW#	ODI	3.3	Indicates that the external battery is low, 47kΩ pull-up on module
A28	ATA_ACT#	O	3.3	LED indicator for the activity of SATA
A29	AC_SYNC	O	3.3	48kHz audio codec synchronization signal
A30	AC_RST#	O	3.3	Reset output for audio codec
A31	GND		PWR	Ground
A32	AC_BITCLK	IO	3.3	12.228MHz audio codec serial clock
A33	AC_SDOOUT	O	3.3	Serial data output to the audio codec
A34	BIOS_DISABLE#	ODI	3.3	Module BIOS disable. Pull low to disable BIOS on module, 10kΩ pull-up on module
A35	THRMTRIP#	O	3.3	Indicates the entering of the CPU in thermal shutdown
A36	USB6-	IO	3.3	USB channel 6 (negative) ⁴⁾
A37	USB6+	IO	3.3	USB channel 6 (positive) ⁴⁾
A38	USB_6_7_OC#	ODI	3.3	USB Over current channels 6 and 7, 10kΩ pull-up on module
A39	USB4-	IO	3.3	USB channel 4 (negative) ⁴⁾
A40	USB4+	IO	3.3	USB channel 4 (positive) ⁴⁾
A41	GND		PWR	Ground
A42	USB2-	IO	3.3	USB channel 2 (negative) ⁴⁾
A43	USB2+	IO	3.3	USB channel 2 (positive) ⁴⁾
A44	USB_2_3_OC#	ODI	3.3	USB Over current channels 2 and 3, 10kΩ pull-up on module
A45	USB0-	IO	3.3	USB channel 0 (negative) ⁴⁾
A46	USB0+	IO	3.3	USB channel 0 (positive) ⁴⁾
A47	VCC_RTC	I	PWR	RTC battery input, nominal 3.0V
A48	EXCD0_PERST#	O	3.3	ExpressCard card 0 reset signal
A49	EXCD0_CPPE#	I	3.3	ExpressCard card 0 request signal
A50	LPC_SERIRQ	IO	3.3	LPC serial interrupt
A51	GND		PWR	Ground
A52	SDVO_CLK+	O	PCIe	Serial digital video clock output (positive) ¹⁾
A53	SDVO_CLK-	O	PCIe	Serial digital video clock output (negative) ¹⁾
A54	SDIO0_DATA0	IO	3.3	SDIO Data 0 ⁵⁾
A55	SDVO_BLUE+	O	PCIe	Serial digital video blue output (positive) ¹⁾
A56	SDVO_BLUE -	O	PCIe	Serial digital video blue output (negative) ¹⁾
A57	GND		PWR	Ground
A58	SDVO_GREEN+	O	PCIe	Serial digital video green output (positive) ¹⁾
A59	SDVO_GREEN-	O	PCIe	Serial digital video green output (negative) ¹⁾
A60	GND		PWR	Ground
A61	SDVO_RED+	O	PCIe	Serial digital video red output (positive) ¹⁾
A62	SDVO_RED-	O	PCIe	Serial digital video red output (negative) ¹⁾
A63	SDIO0_DATA1	IO	3.3	SDIO Data 1 ⁵⁾
A64	PCIE_TX1+	O	PCIe	PCI Express transmit pair 1 (positive) ²⁾
A65	PCIE_TX1-	O	PCIe	PCI Express transmit pair 1 (negative) ²⁾
A66	GND		PWR	Ground

Pin	Signal	Type	Rail	Description
A67	SDIO0_DATA2	IO	3.3	SDIO Data 2 ⁵⁾
A68	PCIE_TX0+	O	PCle	PCI Express transmit pair 0 (positive)
A69	PCIE_TX0-	O	PCle	PCI Express transmit pair 0 (negative)
A70	GND		PWR	Ground
A71	LVDS_A0+	O	LVDS	LVDS channel A signal pair 0 (positive)
A72	LVDS_A0-	O	LVDS	LVDS channel A signal pair 0 (negative)
A73	LVDS_A1+	O	LVDS	LVDS channel A signal pair 1 (positive)
A74	LVDS_A1-	O	LVDS	LVDS channel A signal pair 1 (negative)
A75	LVDS_A2+	O	LVDS	LVDS channel A signal pair 2 (positive)
A76	LVDS_A2-	O	LVDS	LVDS channel A signal pair 2 (negative)
A77	LVDS_VDD_EN	O	3.3	LVDS panel power enable
A78	LVDS_A3+	O	LVDS	LVDS channel A signal pair 3 (positive)
A79	LVDS_A3-	O	LVDS	LVDS channel A signal pair 3 (negative)
A80	GND		PWR	Ground
A81	LVDS_A_CK+	O	LVDS	LVDS channel A clock (positive)
A82	LVDS_A_CK-	O	LVDS	LVDS channel A clock (negative)
A83	LVDS_I2C_CK	ODO	3.3	LVDS I ² C Clock (DDC)
A84	LVDS_I2C_DAT	OD	3.3	LVDS I ² C Data (DDC)
A85	SDIO0_DATA3	IO	3.3	SDIO Data 3 ⁵⁾
A86	KBD_RST#	ODI	3.3	Reset input from optional keyboard controller, 47kΩ pull-up on module
A87	KBD_A20GATE	ODI	3.3	A20 gate input from optional keyboard controller, 10kΩ pull-up on module
A88	PCIE0_CK_REF+	O	PCle	PCI Express clock reference output for all PCIe lanes (positive)
A89	PCIE0_CK_REF-	O	PCle	PCI Express clock reference output for all PCIe lanes (negative)
A90	GND		PWR	Ground
A91-A92	NC	NC		Not Connected
A93	SDIO0_CLK	O	3.3	SDIO Clock output ⁵⁾
A94-A95	NC	NC		Not Connected
A96	GND		PWR	Ground
A97-A99	VCC_Main		PWR	Main power input
A100	GND		PWR	Ground
A101-A109	VCC_Main	I	PWR	Main power input
A110	GND		PWR	Ground
B1	GND		PWR	Ground
B2	GBE0_ACT#	O	3.3	LAN activation indicator LED
B3	LPC_FRAME#	O	3.3	Indicates the start of an LPC cycle
B4	LPC_AD0	IO	3.3	LPC multiplexed address, command and data bus 0
B5	LPC_AD1	IO	3.3	LPC multiplexed address, command and data bus 1
B6	LPC_AD2	IO	3.3	LPC multiplexed address, command and data bus 2
B7	LPC_AD3	IO	3.3	LPC multiplexed address, command and data bus 3
B8-B9	NC	NC		Not Connected
B10	LPC_CLK	O	3.3	LPC clock output, 33MHz, usage of a clock repeater in case of external BIOS not allowed

Pin	Signal	Type	Rail	Description
B11	GND		PWR	Ground
B12	PWRBTN#	ODI	3.3	Power button input (active on falling edge), 47kΩ pull-up on module
B13	SMB_CLK	OD	3.3	SMBus clock
B14	SMB_DAT	OD	3.3	SMBus data
B15	SMB_ALERT#	ODI	3.3	SMBus Alert, can be used to generate an SMI# or to wake the system, 10kΩ pull-up on module
B16-B17	NC	NC		Not Connected
B18	SUS_STAT#	O	3.3	Indicates imminent suspend operation, used to notify LPC devices
B19-B20	NC	NC		Not Connected
B21	GND		PWR	Ground
B22-B23	NC	NC		Not Connected
B24	PWR_OK	I	3.3	Power OK from main power supply
B25-B26	NC	NC		Not Connected
B27	WDT	O	3.3	Indicates that a watchdog time-out event has occurred. The pin remains high until the software clears the bit.
B28	AC_SDIN2	I	3.3	Serial data input 1 from the audio codec ³⁾
B29	AC_SDIN1	I	3.3	Serial data input 1 from the audio codec
B30	AC_SDIN0	I	3.3	Serial data input 0 from the audio codec
B31	GND		PWR	Ground
B32	SPKR	O	3.3	Speaker output
B33	I2C_CLK	OD	3.3	General purpose I ² C clock, on the module provided by EC
B34	I2C_DAT	OD	3.3	General purpose I ² C data, on the module provided by EC
B35	THRM#	ODI	3.3	Over temperature indication input from off-module temperature sensor, 47kΩ pull-up on module
B36	USB7-	IO	3.3	USB channel 7 (negative); configurable as USB client ⁴⁾
B37	USB7+	IO	3.3	USB channel 7 (positive); configurable as USB client ⁴⁾
B38	USB_4_5_OC#	ODI	3.3	USB Over current channels 4 and 5, 10kΩ pull-up on module
B39-B40	NC	NC		Not Connected
B41	GND		PWR	Ground
B42	USB3-	IO	3.3	USB channel 3 (negative) ⁴⁾
B43	USB3+	IO	3.3	USB channel 3 (positive) ⁴⁾
B44	USB_0_1_OC#	ODI	3.3	USB Over current channels 0 and 1, 10kΩ pull-up on module
B45	USB1-	IO	3.3	USB channel 1 (negative) ⁴⁾
B46	USB1+	IO	3.3	USB channel 1 (positive) ⁴⁾
B47-B48	NC	NC		Not Connected
B49	SYS_RESET#	ODI	3.3	Reset button input (active low), 47kΩ pull-up on module
B50	CB_RESET#	O	3.3	Reset output of the module for the carrier board
B51	GND		PWR	Ground
B52-B53	NC	NC		Not Connected
B54	SDIO0_CMD	O	3.3	SDIO command output ⁵⁾
B55	SDVO_STALL+	I	PCIe	Serial digital video stall input (positive) ¹⁾

Pin	Signal	Type	Rail	Description
B56	SDVO_STALL -	I	PCle	Serial digital video stall input (negative) ¹⁾
B57	SDIO0_WP	I	3.3	SDIO write protect input ⁵⁾
B58	SDVO_INT+	I	PCle	Serial digital video interrupt input (positive) ¹⁾
B59	SDVO_INT -	I	PCle	Serial digital video interrupt input (negative) ¹⁾
B60	GND		PWR	Ground
B61	SDVO_TVCLKIN+	I	PCle	Serial digital video TV clock input (positive) ¹⁾
B62	SDVO_TVCLKIN -	I	PCle	Serial digital video TV clock input (negative) ¹⁾
B63	SDIO0_CD#	I	3.3	SDIO card detect input ⁵⁾
B64	PCIE_RX1+	I	PCle	PCI Express receive pair 1 (positive) ²⁾
B65	PCIE_RX1-	I	PCle	PCI Express receive pair 1 (negative) ²⁾
B66	WAKE0#	ODI	3.3	PCI Express wake up input, 1kΩ pull-up on module
B67	WAKE1#	ODI	3.3	General purpose wake up input, 47kΩ pull-up on module
B68	PCIE_RX0+	I	PCle	PCI Express receive pair 0 (positive)
B69	PCIE_RX0-	I	PCle	PCI Express receive pair 0 (negative)
B70	GND		PWR	Ground
B71-B78	NC	NC		Not Connected
B79	LVDS_BKLT_EN	O	3.3	Backlight enable for LVDS display
B80	GND		PWR	Ground
B81-B82	NC	NC		Not Connected
B83	LVDS_BKLT_CTRL	O	3.3	Backlight brightness control for LVDS display
B84-B87	VCC_5V_SBY	I	PWR	Optional standby power input, 5V nominal
B88	NC	NC		Not Connected
B89	VGA_RED	O	A	VGA red output
B90	GND		PWR	Ground
B91	VGA_GRN	O	A	VGA green output
B92	VGA_BLU	O	A	VGA blue output
B93	VGA_HSYNC	O	5	VGA horizontal sync output
B94	VGA_VSYNC	O	5	VGA vertical sync output
B95	VGA_I2C_CK	ODO	3.3	VGA DDC clock output
B96	VGA_I2C_DAT	OD	3.3	VGA DDC data signal
B97	TV_DAC_A	O	3.3	TV DAC channel A
B98	TV_DAC_B	O	3.3	TV DAC channel B
B99	TV_DAC_C	O	3.3	TV DAC channel C
B100	GND		PWR	Ground
B101- B109	VCC_Main	I	PWR	Main power input
B110	GND		PWR	Ground

- 1) Assembly option for higher volumes: SDVO instead of VGA /TV.
- 2) Assembly option for higher volumes: Additional PCIe instead of GLAN
- 3) Assembly option for higher volumes: B28 to B29 on module shorted
- 4) Refer to chapter 4.3.1 USB mapping
- 5) Refer to chapter 3.3.1 SDIO / GPIO signals

3.3.1 SDIO / GPIO signals

On Robin Z5xx V2.0, either the SDIO or GPIO signals can be switched to the COM Express connector through a configuration setting in the BIOS. This feature is not available on Robin V1.0, where the SDIO interface is permanently connected to the COM Express Connector. The BIOS setting is available for Robin V1.0 BIOS, but is not changeable.

COM Express Pin	BIOS setting to "SDIO", Robin V1.0 and V2.0	BIOS setting to "GPIO", Robin V2.0
A54	SLOT0_DATA0	USB_GPIO0
A63	SLOT0_DATA1	USB_GPIO1
A67	SLOT0_DATA2	USB_GPIO2
A85	SLOT0_DATA3	USB_GPIO3
A93	SLOT0_CLK	USB_GPIO4
B54	SLOT0_CMD	USB_GPIO5
B57	SLOT0_WP	USB_GPIO6
B63	SLOT0_CD#	USB_GPIO7

Note: The same GPIO signals are always available on the FFC for both PCB versions 1.0 and 2.0.

3.4. Assignment of additional FFC Connector

Connector: FFC 30 pins, 0.5 mm pitch, bottom contact (example MOLEX 52437-3072)

Pin	Signal	Type	Rail	Description
1	SDIO2_CLK	O	3.3	SDIO channel 2 clock, 24 MHz for SD and SDIO, 48 MHz for MMC
2	GND		PWR	Ground
3	SDIO2_CMD	OD/IO	3.3	SDIO channel 2 command, used for card initialization and transfer of commands, 39kΩ pull-up on module
4	SDIO2_LED	O	3.3	SDIO channel 2 LED output, can be used to drive an external LED over a transistor to indicate transfer on the bus
5	SDIO2_CD#	ODI	3.3	SDIO channel 2 card detect, the present of the card is signaled by pulling the signal to ground, 10kΩ pull-up on module
6	SDIO2_WP	ODI	3.3	SDIO channel 2 write protect, denote the state of the write-protect tab on SD card, pull signal to ground to enable writing, 10kΩ pull-up on module
7	SDIO2_PWR#	O	3.3	SDIO channel 2 power enable, can be used to enable the power being supplied to an SDIO/MMC device
8	VCC_3.3S_OUT	O	PWR	3.3V power output for powering a SDIO device. The power rail is only available in S0 state.
9	SDIO2_DATA0	IO	3.3	SDIO channel 2 data line (channel 2 is 8 bit capable)
10	SDIO2_DATA1	IO	3.3	SDIO channel 2 data line (channel 2 is 8 bit capable)
11	GND		PWR	Ground
12	SDIO2_DATA2	IO	3.3	SDIO channel 2 data line (channel 2 is 8 bit capable)
13	SDIO2_DATA3	IO	3.3	SDIO channel 2 data line (channel 2 is 8 bit capable)
14	SDIO2_DATA4	IO	3.3	SDIO channel 2 data line (channel 2 is 8 bit capable)
15	SDIO2_DATA5	IO	3.3	SDIO channel 2 data line (channel 2 is 8 bit capable)
16	GND		PWR	Ground
17	SDIO2_DATA6	IO	3.3	SDIO channel 2 data line (channel 2 is 8 bit capable)
18	SDIO2_DATA7	IO	3.3	SDIO channel 2 data line (channel 2 is 8 bit capable)
19	VCC_3.3S_OUT	O	PWR	3.3V power output for powering a SDIO device. The power rail is only available in S0 state.
20	USB_CLIENT_DETECT	I	3.3	USB client connect detection, indicates connection to an external USB host has been established, needs voltage level shifter
21	SDIO0_LED	O	3.3	SDIO channel 0 LED output, can be used to drive an external LED over a transistor to indicate transfer on the bus
22	GPIO_0	IO	3.3	General Purpose input/output
23	GPIO_1	IO	3.3	General Purpose input/output
24	GND		PWR	Ground
25	GPIO_2	IO	3.3	General Purpose input/output
26	GPIO_3	IO	3.3	General Purpose input/output
27	GPIO_4	IO	3.3	General Purpose input/output
28	GPIO_5	IO	3.3	General Purpose input/output
29	GPIO_6	IO	3.3	General Purpose input/output
30	GPIO_7	IO	3.3	General Purpose input/output

4. Signal Description

4.1. System Memory

Robin Z5xx modules incorporate fast DDR2 on-board system memory with the following characteristics:

Attribute	Robin Z5xx V1.0	Robin Z5xx V2.0
Size	512MByte	512MByte / 1GByte / 2GByte
Memory organization	X16 bits	X8 bits
Memory speed	533MT/s for Z530 (400MT/s for Z510)	533MT/s for Z530 (400MT/s for Z510)

4.2. Serial ATA

The Serial ATA (SATA) interface is provided through the JMH330 IDE to SATA Bridge from JMicron. No additional driver is required for the SATA interface.

4.3. USB Interface

The US15W (System Controller Hub on the Robin module) features Enhanced Host Controller Interface (EHCI) with 8 USB ports. All 8 ports support USB high speed (480Mbit/s). However, it should be noted that only 6 of these ports support low speed (1.5Mbit/s) and full speed (12Mbit/s).

7 USB ports are available through the COM Express™ connector. Port 5 of the US15W is used for communication with the Robin Embedded Controller and is therefore not available on the module connector..

4.3.1 USB mapping

The following table shows how the US15W USB signals are mapped to the COM Express USB channels.

COM Express™ Connector USB channel	US15W USB Port
0	0
1	1
2	3
3	4
4	6 (480MBit only)
5	Not available
6	7 (480MBit only)
7 (client)	2 (client)

4.3.2 USB client

USB port 7 on the connector can be configured as a client. The presence of a host device connected to the client port is detected by monitoring the USB bus voltage. The detection mechanism can be implemented using a level-shifting circuit (as shown below) connected to the USB_CLIENT_DET signal (pin 20 of the FFC connector on the Robin module).

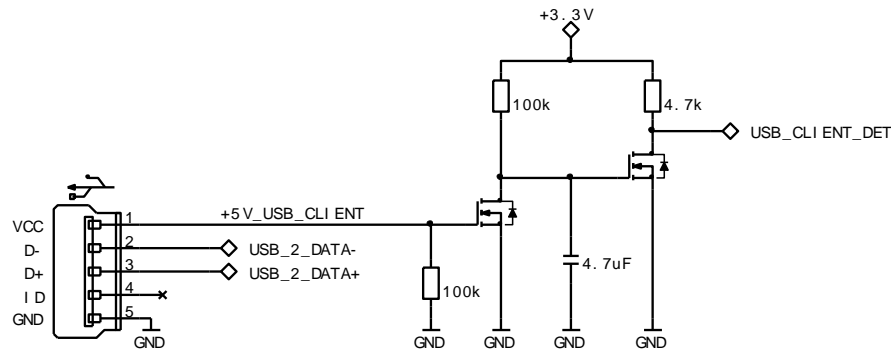

4.4. Ethernet Controller

The Robin Z5xx module features an onboard RTL8111C/D gigabit Ethernet controller from Realtek which supports a 10/100/1000 Base-T interface. This controller is directly connected to the PCI Express interface of the US15W. The device auto-negotiates the use of the different speeds and includes features such as crossover detection with auto-correction, polarity correction and cross-talk cancellation.

For high volumes, the Robin module can be assembled with the RTL8102E Ethernet controller instead of the RTL8111C/D. This offers a suitable solution for very price sensitive, high volume projects requiring only a 10/100 Base-T fast Ethernet controller (please contact Toradex for further information).

4.5. PCI Express

The US15W chipset features two x1 PCI Express lanes. PCIe lane 0 of the US15W is directly available at the COM Express™ connector. PCIe lane 1 is connected directly to the Ethernet controller and is not available for general use.

4.6. ExpressCard

The Robin Z5xx module supports the two additional signals required for the ExpressCard interface (card detect and card reset). The ExpressCard interface makes use of both a USB port and a single PCI Express lane (although an attached ExpressCard device may only make use of one of these interfaces).

4.7. SDIO, SD Card and MMC

The Intel® US15W features 3 SDIO buses. Each SDIO bus can be used for SD cards, MultiMediaCards (MMC), as an SDIO interface or CE-ATA interface. The SD card and the SDIO interface can run in either 1 bit or 4 bit mode, whereas MMC supports an additional 8 bit transfer mode. Only SDIO slot 2 of the US15W is 8 bit capable; the other two are only 4bit capable.

SDIO slot 1 is available on the Robin module as MicroSD card holder. Slot 0 is on the COM Express™ connector (see chapter 3.3.1) and slot 2 is available on the 30 pin FFC connector. This connector also provides 3.3V power supply for SD or MMC cards. Please note that as the maximum power rating of

the 3.3V supply on this connector is limited, an additional power supply may be required if the connected SDIO device has a power requirement which exceeds this rating.

4.8. VGA

The Robin module features a Chrontel SDVO to VGA and TV out converter CH7022. Please refer to the datasheet for more information.

For application specific/custom carrier board designs, remember to include the **150R** load resistors required at each of the VGA color outputs.

For high volumes, it is an assembly option not to fit the CH7022. The SDVO signals would then be routed to the COM Express connector. Please contact Toradex for further information regarding assembly options.

4.9. TV out

The Robin module features a Chrontel SDVO to VGA and TV out converter CH7022. Please refer to the datasheet for more information.

For application specific/custom carrier board designs, remember to include the **150R** load resistors required at each of the TV outputs.

For high volumes, it is an assembly option not to fit the CH7022. The SDVO signals would then be routed to the COM Express connector. Please contact Toradex for further information regarding assembly options.

The TV out signals can be configured as follows:

COM Express signal	Composite video	Component video	S-Video
TV_DAC_A	CVBS	Chrominance (Pb)	Not used
TV_DAC_B	Not used	Luminance (Y)	Luminance analog signal (Y)
TV_DAC_C	Not used	Chrominance (Pr)	Chrominance analog signal (C)

4.10. Robin Z5xx Module LEDs

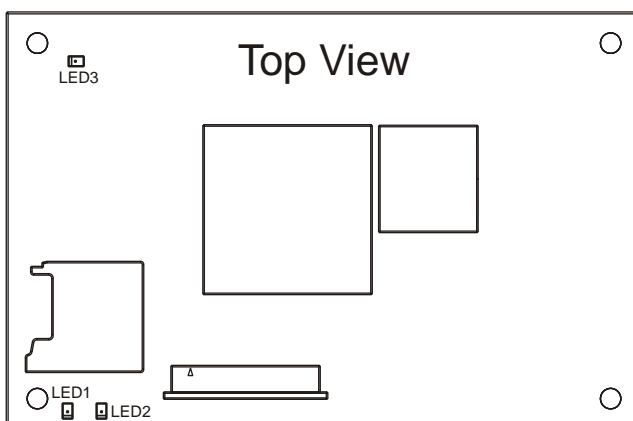

Note: Robin Z5xx V1.0 shown; placement of the LEDs is the same for Robin V2.0.

LED1: Activity indication of the on board MicroSD slot (SDIO channel 0)

LED2: Activity indication of the SDIO channel 1 (available on COM express connector)

LED3: On board flash drive and SATA bridge activity indication. The LED shows the activity parallel to the ATA_ACT# signal (pin A28 on COM express connector).

4.11. LPC

The LPC interface is a Low Pin Count PCI bus. Components on the carrier board such as Super IO or an external BIOS are connected to this bus.

Note for external LPC devices: Don't use a clock repeater on the carrier board for the clock signal of the LPC.

5. Power Supply

5.1. Power States

State	Common Names	Behavior
G3	Mechanical Off	All power supplies except the RTC battery are removed. The power consumption of the system is almost zero; only the RTC circuit consumes a small amount of power
S5	Soft Off	Only the embedded controller on the module is powered. The embedded controller waits for the power button to be pushed before starting the system. The power consumption in this state is very low.
S4	Suspend to Disk Hibernation	The contents of RAM are written to a non-volatile storage medium (e.g. hard disc). This allows recovery of the system to the state prior to entering suspend or hibernate. From the hardware perspective, this state is equal to S5. The system is off except for the embedded controller being powered. The embedded controller waits for the power button to be pushed before starting the system. The power consumption in this state is very low. The Robin hardware does not distinguish between S4 and S5.
S3	Suspend to RAM Stand by, Sleep	The RAM subsystem is powered for a fast recovery of the system. Power supplies that are not required are switched off. Wake on LAN is supported in this state (hence the network subsystem is powered). The Robin module requires the main power supply to generate the standby power supply.
S0	On	The system is working. All power supplies are switched on. The power consumption depends on the CPU and peripheral load.

The COM Express Connector features three signals for signaling the different power states to the carrier board. As the Robin module hardware does not distinguish between power states S4 and S5, SUS_S4# and SUS_S5# are essentially the same signal.

State	SUS_S5#	SUS_S4#	SUS_S3#
G3	NA	NA	NA
S5	Low	Low	Low
S4	Low	Low	Low
S3	High	High	Low
S0	High	High	High

5.2. Power Supply

The Robin modules are designed to run from a single power supply with a wide nominal input voltage range of +5V to +12V. Two power supplies are optional: a +5V standby power supply and a +3V battery power supply (used to power the real-time clock on the module).

If the standby power supply is not provided by the carrier board, the Robin module will generate the required standby power from the main power supply using a linear voltage regulator. Hence, the Robin module supports both the S4 and S5 power states even if the standby power supply is absent, as long as the main power supply is present.

The RTC power supply is powered in parallel by both the standby power supply and the 3V battery power supply. This ensures that the real-time clock is running as long as either one of these power supplies is present. Important: a diode must be placed between RTC Battery and the RTC Voltage pin of the module connector.

5.2.1 AC Power Adaptor

Depending upon the specific hardware configuration, it is likely that the power supply to the carrier board will be forwarded directly to the Robin module (this is true for Lily V1.0, V1.1, V2.0, V2.1 and Daisy V1.0, V1.1). If an AC power adaptor is being used, please ensure that its output voltage is never beyond the limits of the module and carrier board. Simple AC power adaptors may have significantly higher output voltages than their nominal voltage in no-load operation; usage of such power adaptors can damage both the Robin Z5xx module and carrier board.

5.2.2 ATX-Like Configuration using SUS_S5# as PS_ON

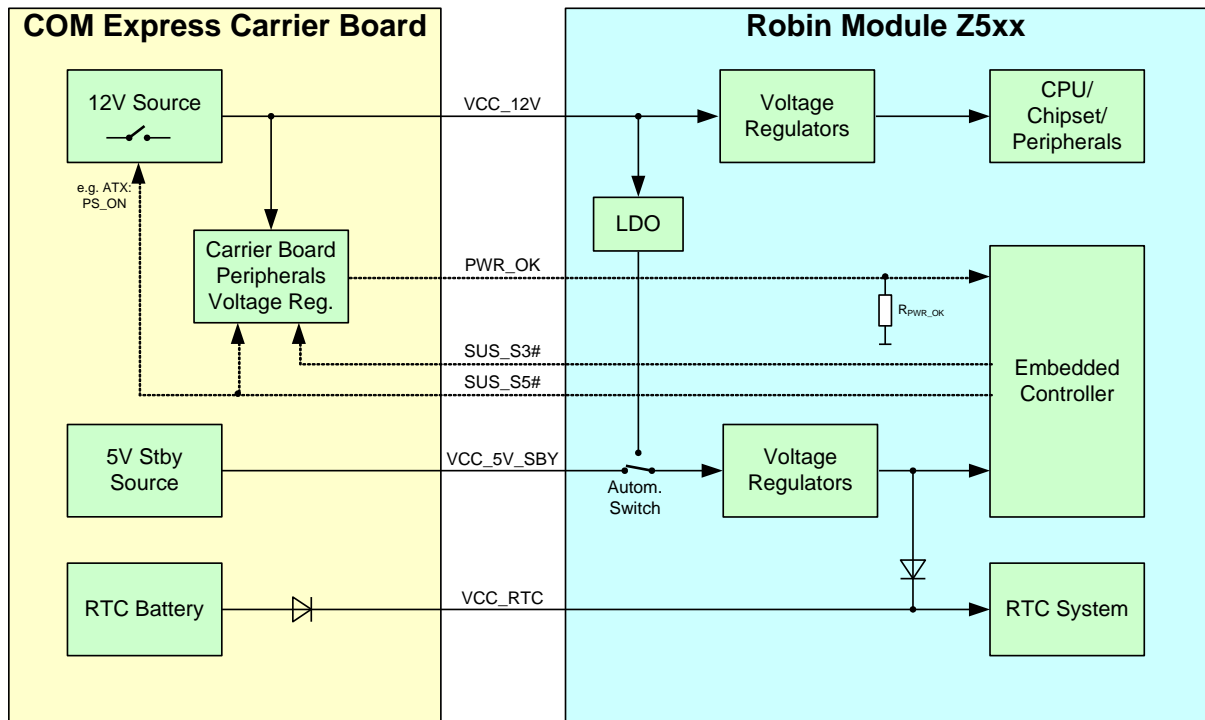

If the carrier board features a 5V standby power supply, the main power rail can be switched off in power states S5 and S4. The SUS_S5# or SUS_S4# signal can be used for switching the main power supply. If the carrier board features an ATX Power supply, the SUS_S5# signal is used to drive the PS_ON pin of the ATX power supply through a level shifter. The Power good signal from the ATX power supply can be used directly without level shifter as the PWR_OK signal for the Robin module.

With this power control method, the carrier board must manage the following power sequence:

1. Robin module de-asserts the SUS_S5# and SUS_S4# signal.
2. The carrier board must switch on the main power supply and the necessary power supplies for the peripherals on the carrier board.
3. If all required power supplies on the carrier board are stable, the carrier board shall indicate this to the Robin module through the PWR_OK signal. This must be done within 15 seconds of the SUS_S5# signal being de-asserted. Otherwise the Robin module shall enter the power state S5 (power fail). The Robin module can be configured to retry the power up sequence after 1 minute (see section 6.5.1).
4. The Robin module ramps up all the necessary power supplies to enter power state S3 and de-asserts the SUS_S3# signal.
5. The Robin module continues its power up process by ramping up the remaining on-board power supplies, releasing the reset signal and booting.

5.2.3 ATX-Like Configuration using SUS_S3# as PS_ON

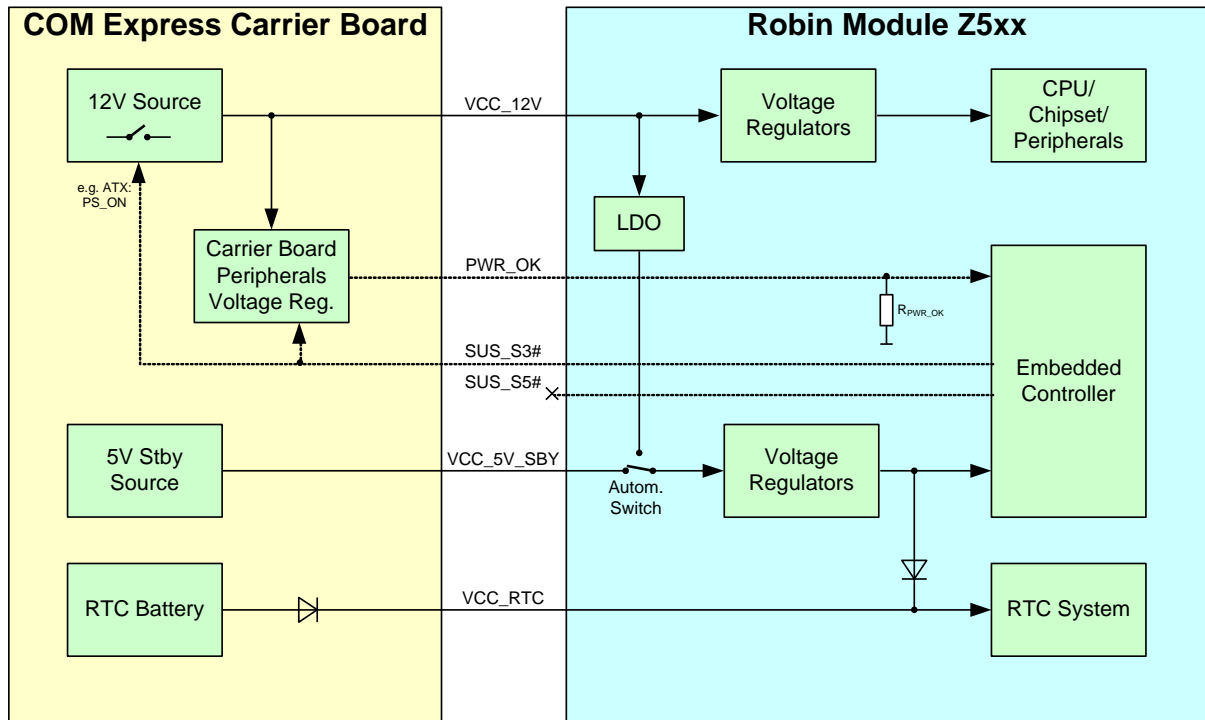

It is also possible to use the signal SUS_S3# for controlling the main power supply, which is the mechanism employed by some commercially available COM Express carrier boards. To support this power control method, the Robin module requires a change to a setting in the embedded controller which enables S3 Signaling Mode. When operating in S3 Signaling Mode, the module de-asserts both SUS_S3# and SUS_S5# simultaneously. Section 6.5.2 describes this in more detail. S3 Signaling Mode can be configured using the Toradex Z5xx Tweaker tool.

For new designs, Toradex does not recommend using this power control method and hence hardware configuration, as it is not possible for the carrier board to differentiate between power states S5 and S3.

With this power control method, the carrier board must manage the following power sequence:

1. The Robin module de-asserts signals SUS_S5#, SUS_S4# and, if S3 Signaling Mode is enabled, SUS_S3#.
2. The carrier board must switch on the main power supply and the necessary power supplies for any carrier board peripherals.
3. If all required power supplies on the carrier board are stable, the carrier board must assert the PWR_OK signal within 10 seconds of the de-assertion of signal SUS_S5#. In the event that this fails to happen, the Robin module will de-assert signal SUS_S3# if it has not already done so in step 1 (this allows the Robin module to successfully power on in order to enable S3 Signaling Mode). If a further 5 seconds elapses without the PWR_OK signal asserted, the Robin module returns to power state S5 (power fail). The embedded controller can be configured to retry the power up sequence after 1 minute (see section 6.5.1).
4. The module ramps up all the necessary power supplies to enter power state S3.
5. The Robin module continues its power up process by ramping up the remaining on-board power supplies, releasing the reset signal and booting.

Note that it is very important to enable S3 Signaling Mode when using this power control method, otherwise the shut-down and suspend power modes will not function correctly, and an additional 10 seconds will be added to the power on time.

5.2.4 Configuration without Standby Supply

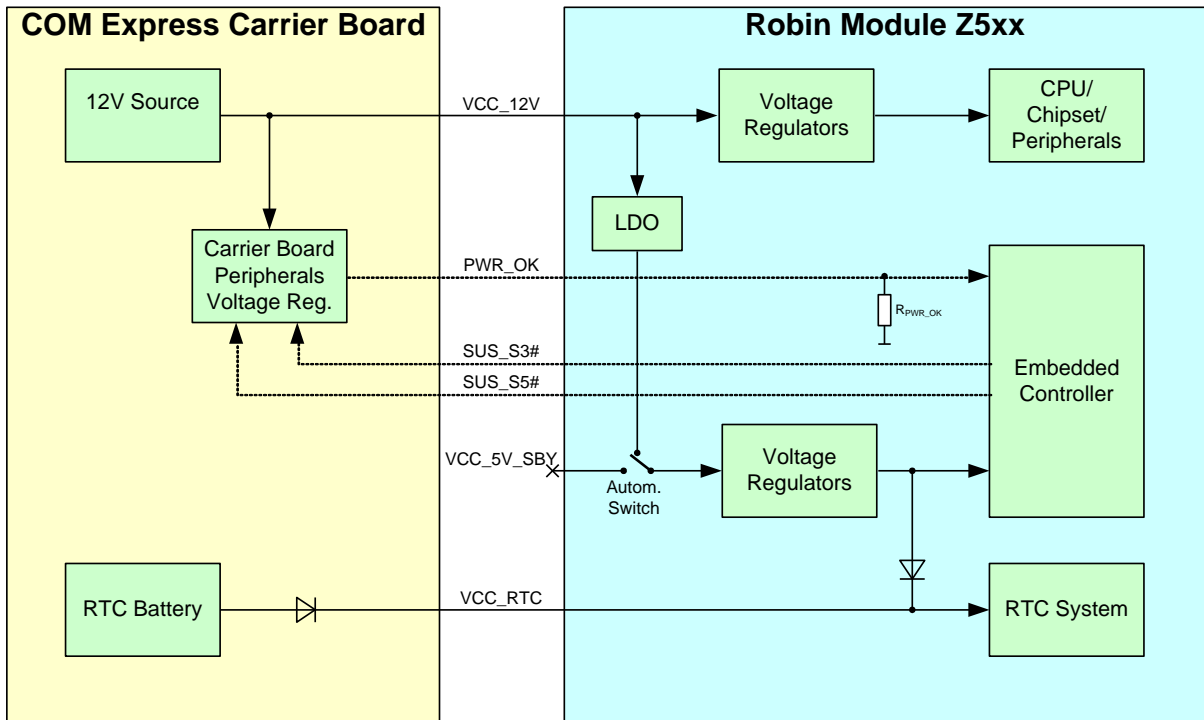

If the VCC_5V_SBY is not provided by the COM Express carrier board, the Robin module will automatically generate its own standby power supply from the main power supply. It is therefore still possible to make use of the power states S4 and S5 if the main power supply is available. In this configuration, the standby power supply is generated using a linear voltage regulator, and so the Robin module power consumption whilst in power state S3, S4 or S5 is slightly higher than when the standby power supply is provided by the carrier board (power consumption measurements are published in section 9.1).

By default, the embedded controller is programmed to start the system as soon as the main power supply is available if the standby power supply from the carrier board is not available. The Robin module can, however, be configured to stay in the power state S5 even after the main power supply is made available. Section 6.5.1 describes the configuration of this behavior.

5.2.5 Minimum Power Configuration

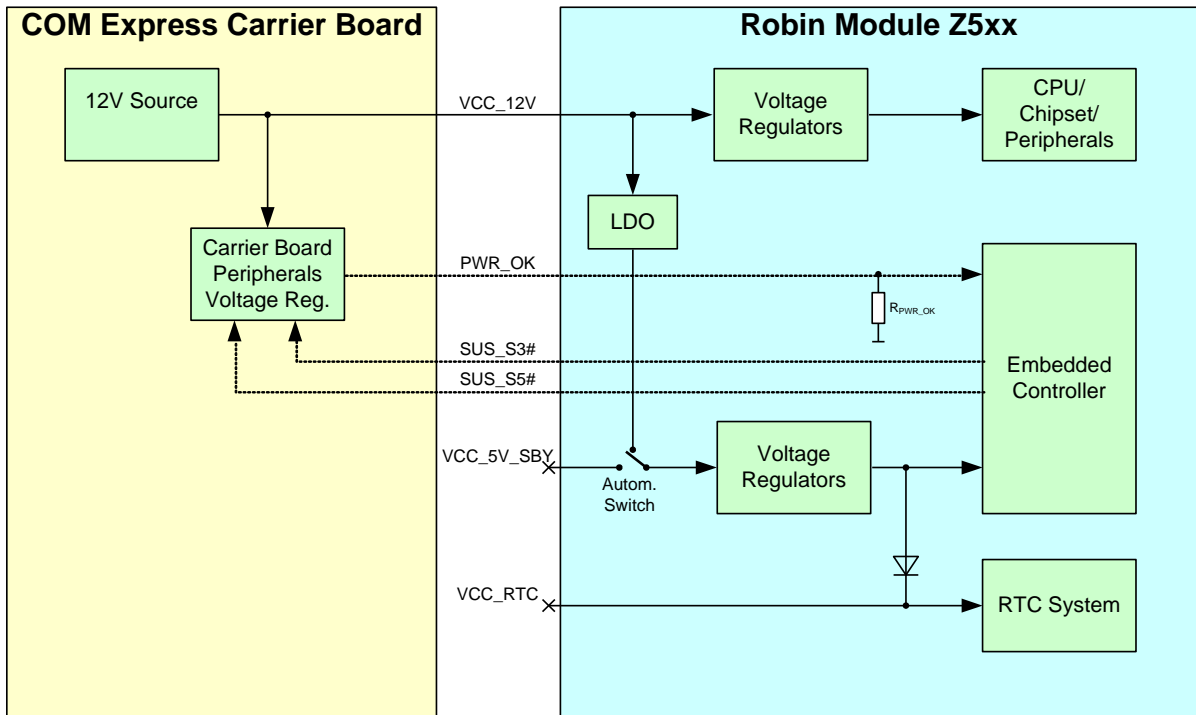

In the minimum power configuration, the carrier board only provides the main power supply to the Robin module. As long as the main power supply is available, the real time clock will run. This configuration may be suitable for battery powered systems with a non-removable main battery, or for systems without the requirement for a real time clock.

5.3. Power Sequences

The following signals are shown in the power control sequence diagrams:

Name	Module Direction	Description
5V_SBY	Input	Standby voltage
PWR_BTN#	Input	Power button
SUS_S5#	Output	Module output that indicates the system is in SoftOff state
12V_Main	Input	Primary power input: 12V nominal
PWR_OK	Input	Power OK from main power supply
Module S3 Power Rails		Module power rails that are used in S3 state (no need by carrier board)
SUS_S3#		Indicates the system is suspended to RAM
5V_CB		Carrier board 5V supply (no need by module)
3.3V_CB		Carrier board 3.3V supply (no need by module)
Module S0 Power Rails		Module power rails that are used in S0 state (no need by carrier board)
CB_RESET#	Output	Reset output of the module for the carrier board

5.3.1 G3 to S0 controlled by Power Button

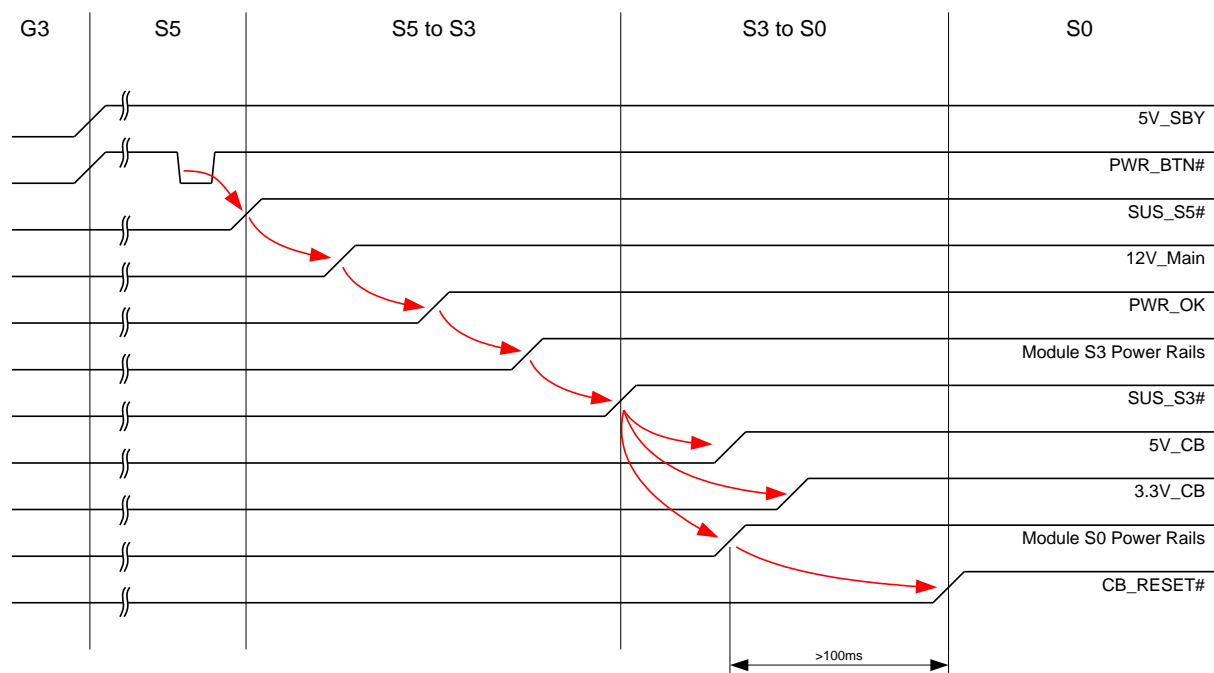

The above diagram shows the behavior if the boot mode is set to automatic and the standby voltage ramps up before the main power supply. Please refer section 6.5.1 for more information to the boot modes.

Important: The 12V_Main voltage needs to ramp up continuously if the boost converter is enabled. Otherwise, the boost converter may be damaged during voltage drops.

5.3.2 G3 to S0 without Waiting for Power Button

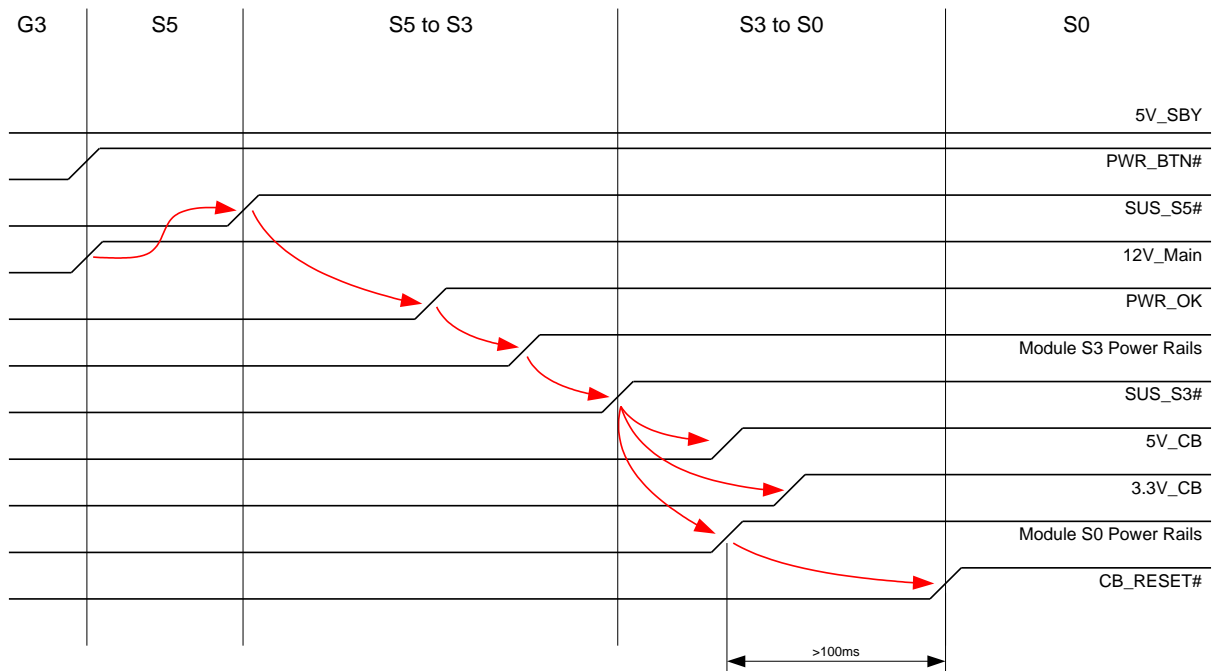

The diagram shows the behavior if the boot mode is set to automatic and the main power supply voltage ramps up with no standby supply available. If boot mode is set to boot always, the same behavior can be achieved even if the standby power supply is available. Please refer section 6.5.1 for more information to the boot modes.

Important: The 12V_Main voltage needs to ramp up continuously if the boost converter is enabled. Otherwise, the boost converter may be damaged during voltage drops.

5.3.3 S0 to S5 Shutdown

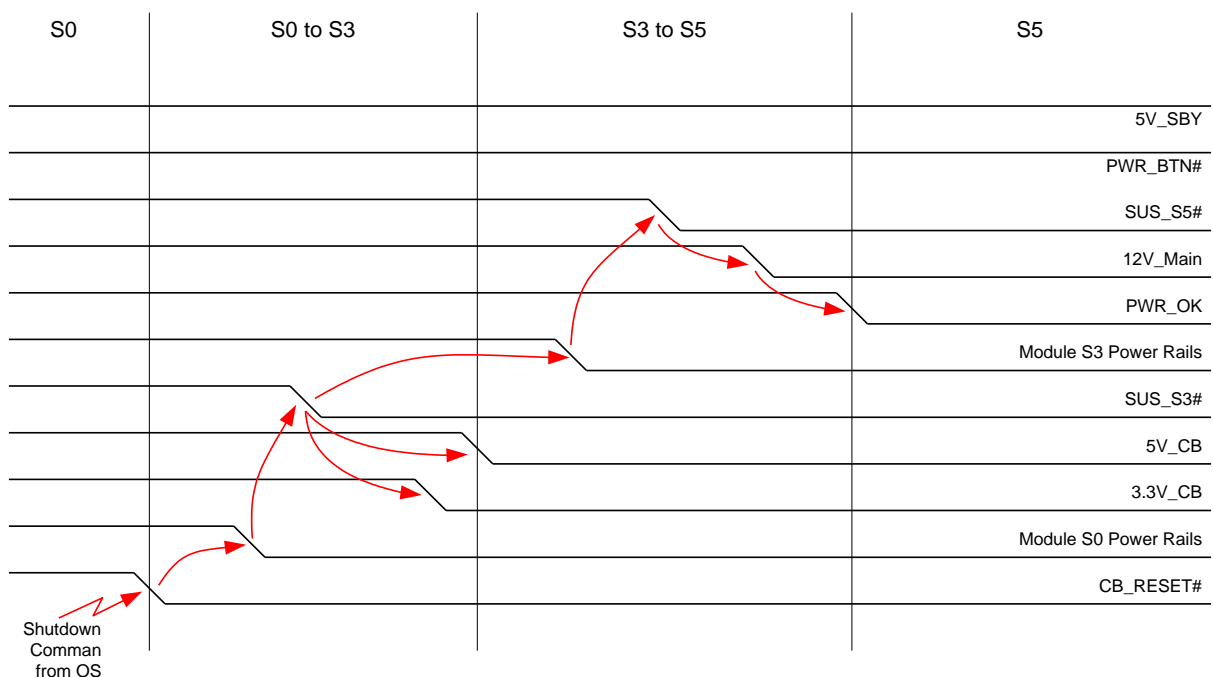

Important: The 12V_Main voltage needs to ramp down continuously if the boost converter is enabled. Otherwise, the boost converter may be damaged during voltage drops.

5.3.4 S0 to S3 Suspend to RAM

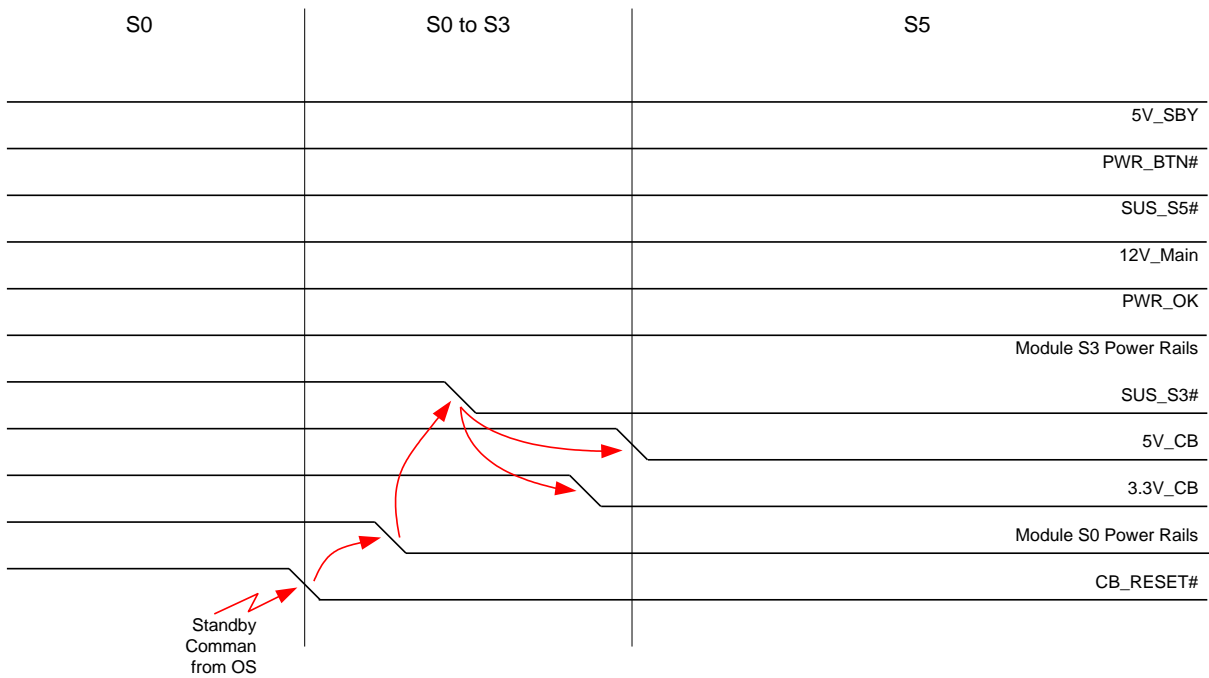

Some carrier board power supplies may not be switched off in the event that they are used by a wakeup source.

5.3.5 S3 to S0 Resume

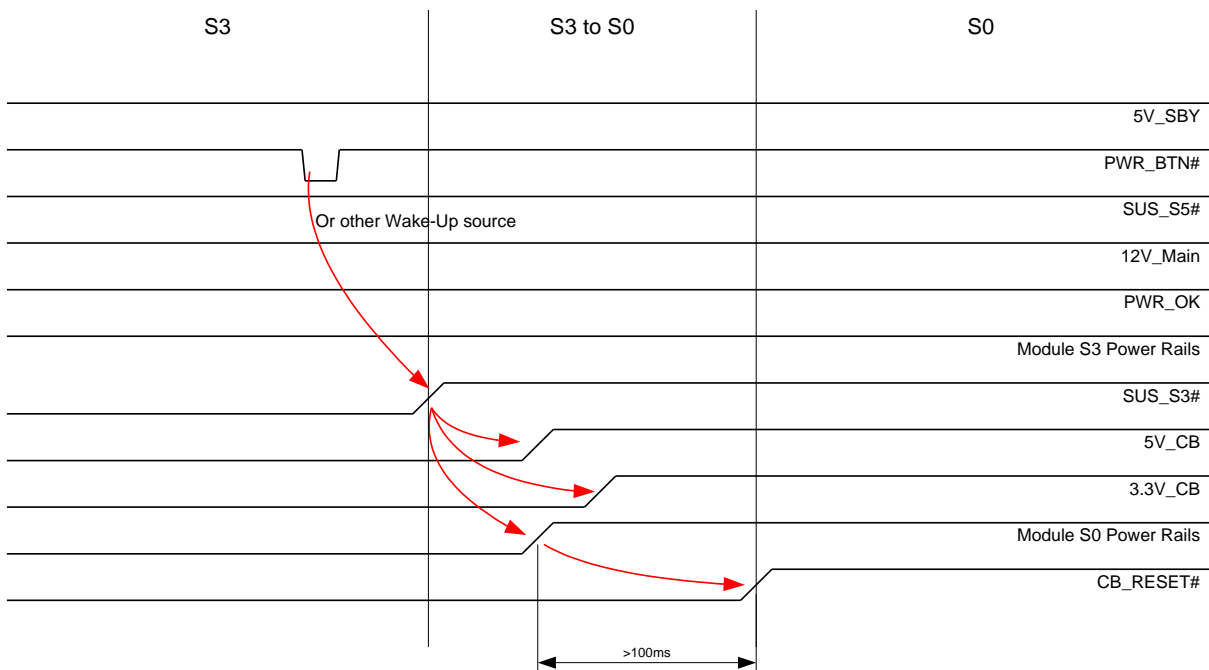

The above diagram shows the power up sequence when the power button is used as a wake-up source. Please refer to section 0 for other wake-up sources.

5.3.6 Power Button Emergency Shutdown

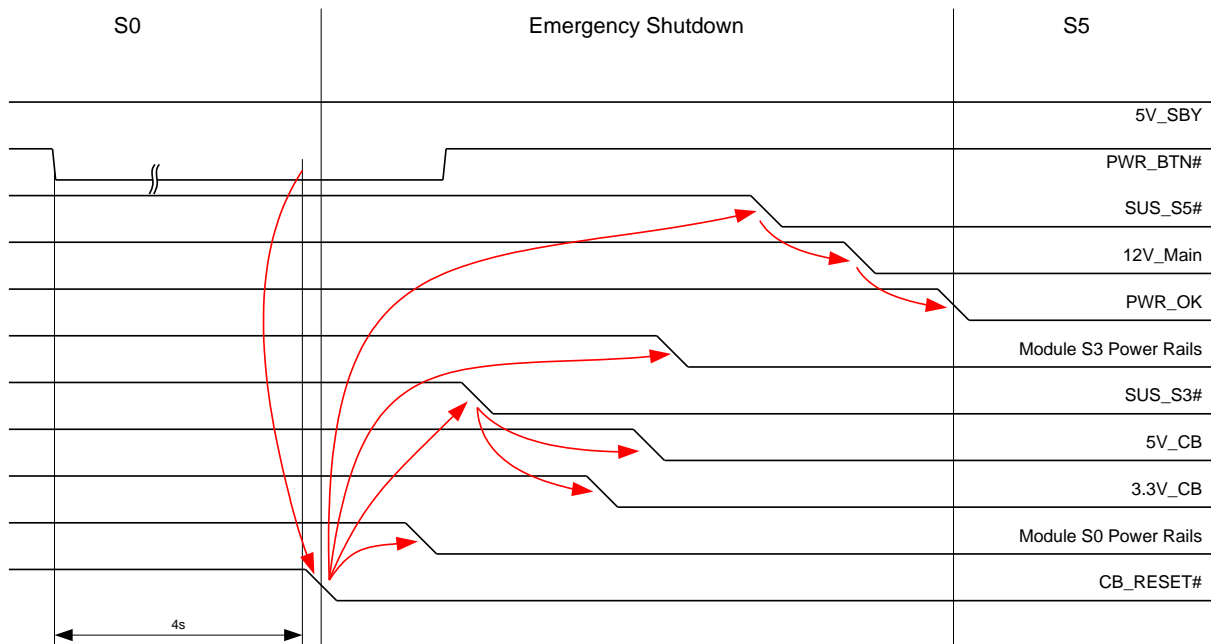

The system can be forced to shut down by pressing and holding down the power button more than 4 seconds. The shutdown proceeds without verifying that each signal is de-asserted in the correct sequence.

Wakeup Events

The following wake-up sources are available for waking up the system from the S3 state:

- Power Button
- Wake on LAN signal (WOL)
- WAKE0# (Pin B66) PCI Express wake up signal
- WAKE1# (Pin B67) General purpose wake up signal

The following wake-up sources are available for waking up the system from the S5 and S4 state:

- Power Button
- Ramping up of main power or standby voltage in combination with a compatible boot mode setting (see section 6.5.1).

6. Robin Embedded Controller

The embedded controller on the Robin computer module is a PSoC CY8C24794 from Cypress. The PSoC is a powerful 8 bit microcontroller with USB interface and analog user blocks. The key responsibilities of the embedded controller are to provide the power management, watchdog functionality, user GPIO system and I2C interface.

The firmware used in the Robin Embedded Controller is compatible with the Toradex Oak Sensor family. For core functionality, the same software libraries can be used. The embedded controller appears in the operating system as standard USB Human Interface Device (HID). Therefore, for all major operating systems, no additional drivers are necessary. The communication protocol implemented in the embedded controller makes use of three different report modes. The INTERRUPT OUT report mode is used to control the GPIO ports of the embedded controller and to service the watchdog in real time with a maximum latency of 1ms. The INTERRUPT IN report mode allows the embedded controller to transmit real time data relating to GPIO status and I2C bus data back to the main processor. The FEATURE report mode is independent from the interrupt scheduled report modes and is used as bidirectional non-real time communication channel for configuring power management, watchdog and GPIO settings.

6.1. INTERRUPT OUT Report Contents (Real time data)

The interrupt out report contains two commands for switching the 8 I/O channels, watchdog servicing information and I²C commands.

Byte Position	Size [Bit]	Name	Function
0	8	OUT1CMD	Command 1 for I/O port bit[7..0]
1	8	OUT2CMD	Command 2 for I/O port bit[7..0]
2	8	WDS	Watchdog servicing
3	8	I2C_ID	Number to identify the I ² C message
4	8	I2C_CMD	Command for the I ² C Interface
5	8	I2C_ADDR	Slave Address for I ² C command
6	8	I2C_COUNT	Number of Bytes to send/receive (I ² C)
7... 11	5 x 8	I2C_DATA_OUT0 ... I2C_DATA_OUT4	I2C Data to send (payload 5 bytes)

6.1.1 GPIO Command

The output report for the I/O consists of two commands. The following table defines these commands.

OUT2CMD[x]	OUT1CMD[x]	Function
0	0	Set pin[x] to 0
0	1	Set pin[x] to 1
1	0	Toggle pin[x]
1	1	Hold previous state of pin[x]

6.1.2 Watchdog

The watchdog is serviced using the WDS byte. An interrupt out report with a WDS value unequal to the previous sent value will service the watchdog. Populating the WDS byte with a simple toggle signal or incremental counter value will be sufficient to service an enabled watchdog.

6.1.3 I²C interface

I2C_ID: Identification number. This ID will be copied to the Interrupt In report if the I²C read transaction from the I²C slave device was successful. This number can be used to identify the corresponding Interrupt In report.

I2C_CMD[1..0]: 0x0 = Perform complete transfer from Start to Stop (standard transfer)
 0x1 = Send Repeat Start instead of Start (used for combined transfer)
 0x2 = Execute transfer without a Stop (use for combined transfer)

I2C_CMD[2]: 0 = Write to the slave device
 1 = Read from the slave device

I2C_CMD[3]: 0 = Executes no I²C transfer
 1 = Executes an I²C transfer

I2C_ADDR: Address of the I2C slave device. Valid addresses are from 0 to 127

I2C_COUNT: Number of bytes to send to or receive from the device. The maximum number is 5 for transmit data and 4 for receive data. If more bytes are required for either transmit or receive data, a combined transfer can be used.

I2C_DATA_OUT: Payload data for transmission to the slave device (maximum 5 bytes)

6.2. INTERRUPT IN Report Contents (Real time data)

Byte Position	Size [Bit]	Name	Function
0	16	FRAME	Frame number (millisecond resolution)
2	8	IO_DATA	GPIO values
3	8	I2C_ID	Identifier of the I ² C message
4	8	I2C_COUNT	Number of Bytes received (I ² C)
5... 8	4 x 8	I2C_DATA_IN0 ... I2C_DATA_IN3	Received I2C Data (payload 4 bytes)
9	8	STATE	Status of the System

6.2.1 Frame Number

The frame number is a millisecond counter that counts up to 2048 before rolling over. The USB host controller polls the embedded controller requesting an interrupt in report every millisecond, incrementing the frame number for each request. The embedded controller copies this frame number into the interrupt in report to allow the corresponding request to be easily identified. The frame number can therefore be used for measuring the time between two interrupt in report requests or identify lost messages.

6.2.2 GPIO Values

This byte contains the actual state of all 8 GPIOs.

6.2.3 I²C interface

I2C_ID: Identification number. This ID will be copied to the Interrupt Out report if the I²C read transaction from the I²C slave device was successful. This number can be used to identify the corresponding Interrupt In report.

I2C_COUNT: The COUNT contains the number of bytes in the payload received from the device if a new I2C message has been received successfully. If no new message has been received from the device, this value will be zero.

I2C_DATA_OUT: Payload received from the slave device (maximum 4 bytes)

6.2.4 System Status

STATE[0]: BOOST_CONVERTER_ENABLED: This bit indicates the actual state of the main power boost converter. A value of 1 indicates the boost converter is enabled. The voltage range of the main power supply can be 5 to 14V.

STATE[1]: BATLOW#: This bit represents the actual state of the BATLOW# pin of the COM Express connector (pin A27).

STATE[2]: WDT: This bit represents the actual state of the WDT pin on the COM Express connector (pin B27). This pin is latched high if a watchdog event occurred during the current power cycle.

STATE[3]: reserved

STATE[4]: THERMTRIP#: This bit represents the actual state of the THERMTRIP# pin on the COM Express connector (pin A35). This pin is latched low if the system was shut down due to an over temperature event during the current power cycle.

- STATE[5]: PWRBTN#: This bit represents the actual state of the PWRBTN# pin on the COM Express connector (pin B12). The bit can be used to read the state of the power button in a user application.
- STATE[6]: reserved
- STATE[7]: 5V_STBY_AV: This bit is high if the standby voltage rail on the COM Express connector is available.

6.3. FEATURE Report Commands for GPIO

The feature report commands are used for writing and reading embedded controller settings. Settings can be written into either RAM or flash. The settings stored in RAM are volatile and will be lost when the main power supply and standby power supply are disconnected. Settings written to flash will be automatically copied into RAM and will take effect immediately. Please also refer to the “Programming Guide to the Oak Sensor Family” for a detailed description of using feature report commands.

6.3.1 Report Mode

Byte#	0	1	2	3	4	5
Content	GnS	Tgt	0x01	0x00	0x00	RPTMODE

GnS: 0 = Set
1 = Get

Tgt 0 = RAM
1 = Flash

RPTMODE: 0 = After Sampling (factory default)
1 = After Change

6.3.2 Sample Rate

The sample rate setting defines the periodic rate at which the embedded controller reads the status of all hardware signals and executes I2C communication requests. If Report Mode is set to 0, then data will always be returned to the host on a feature report request after a new sampling event has taken place. If Report Mode is set to 1, then data shall only be returned to the host on a feature report request if the requested data changed between two sampling events.

Byte#	0	1	2	3	4	5	6
Content	GnS	Tgt	0x02	0x01	0x00	SampRate LSB	SampRate MSB

GnS: 0 = Set
1 = Get

Tgt 0 = RAM
1 = Flash

SampRate: Sample Rate [ms] (factory default 50 ms)

6.3.3 GPIO Direction

This configures the GPIO pins as inputs or outputs.

Byte#	0	1	2	3	4	5
Content	GnS	Tgt	0x01	0x01	0x00	DIR7..DIR0

GnS: 0 = Set
1 = Get

Tgt 0 = RAM
1 = Flash

DIR7..DIR0: 0 = Configures pin as input (factory default for Pin 3 to 0)
 1 = Configures pin as output (factory default for Pin 7 to 4)

6.3.4 GPIO Output Mode

This configures individual GPIOs to operate as either CMOS compatible push-pull or open drain outputs.

Byte#	0	1	2	3	4	5
Content	GnS	Tgt	0x01	0x02	0x00	OM7..OM0

GnS: 0 = Set
 1 = Get

Tgt 0 = RAM
 1 = Flash

OM7..OM0: 0 = Configures pin as CMOS compatible push-pull output (factory default)
 1 = Configures pin as open drain output
 This setting is ignored if the pin is configured as input

6.3.5 Standby Configuration

This configures the behavior of the GPIO pins that are configured as output in the S3, S4 and S5 state.

Byte#	0	1	2	3	4	5
Content	GnS	Tgt	0x01	0x03	0x00	StbB7.. StbB0

GnS: 0 = Set
 1 = Get

Tgt 0 = RAM
 1 = Flash

StbB7..StbB0: 0 = Configures pin as high Z during standby (factory default)
 1 = Configures pin not to change state during standby

Note: For power saving set all pins to the standby configuration “high Z during standby”. Otherwise, depending on the external circuit, the board can consume more current in standby mode than specified.

6.4. FEATURE Report Commands for Watchdog

6.4.1 Watchdog mode

Please exercise caution when changing watchdog settings. It is recommend that new settings be tested by firstly writing them to RAM before committing them to flash. This way, the settings stored in flash can be restored by unplugging all power supplies.

Byte#	0	1	2	3	4	5
Content	GnS	Tgt	0x01	0x05	0x00	WDT_M

GnS: 0 = Set
 1 = Get

Tgt 0 = RAM
 1 = Flash

WDT_M: 0 = Watchdog is switched off (factory default)
 1 = Watchdog initiates a system reset if a watchdog event occurs.
 The embedded controller switches off the watchdog after the fifth system reset without it having been serviced in between resets. This allows recovery from an erroneous watchdog configuration.

- 2 = Only the WDT pin on the COM Express™ will be asserted when a watchdog event occurs; the system will not be reset.

6.4.2 Strobe Interval

The strobe interval defines the maximum permitted period between watchdog servicing events without the occurrence of a watchdog event.

Byte#	0	1	2	3	4	5	6
Content	GnS	Tgt	0x02	0x02	0x00	WDT_Int LSB	WDT_Int MSB

GnS: 0 = Set
1 = Get

Tgt 0 = RAM
1 = Flash

WDT_Int: Strobe interval [10^{-1} s] (Factory Default 100 = 10s)
minimum value: 0.1s, maximum value: 100min

6.4.3 Watchdog Enable Delay

This defines a delay period after system start within which the watchdog must be serviced for the first time. Please set this value very **carefully** and test it by changing it only RAM before committing changes to flash.

Byte#	0	1	2	3	4	5	6
Content	GnS	Tgt	0x02	0x03	0x00	WDT_Dly LSB	WDT_Dly MSB

GnS: 0 = Set
1 = Get

Tgt 0 = RAM
1 = Flash

WDT_Dly: Watchdog enable delay [10^{-1} s] (factory default 1200 = 2min)
minimum value: 1s, maximum value: 100min

6.4.4 Watchdog Source

This configures the source responsible for servicing the watchdog.

Byte#	0	1	2	3	4	5
Content	GnS	Tgt	0x01	0x06	0x00	WDT_Source

GnS: 0 = Set
1 = Get

Tgt 0 = RAM
1 = Flash

WDT_Source[0]: 0 = USB Interrupt out report not used for servicing
1 = USB Interrupt out report used for servicing (factory default)

WDT_Source[1]: 0 = USB feature report not used for servicing
1 = USB feature report used for servicing (factory default)

WDT_Source[2]: 0 = USB host polling not used for servicing (factory default)
1 = USB host polling used for servicing

WDT_Source[3]: 0 = US15W GPIO not used for servicing (factory default)
1 = US15W GPIO used for servicing

WDT_Source [7..4]: Must be set to 0

6.4.5 Service Watchdog

This feature report command services the watchdog.

Byte#	0	1	2	3	4
Content	0x00	0x80	0x00	0x01	0x00

6.4.6 Reset Watchdog Pin

This feature report command resets the state of the WDT pin on the COM Express™ connector.

Byte#	0	1	2	3	4
Content	0x00	0x80	0x00	0x02	0x00

6.5. FEATURE Report Commands for Power Management

6.5.1 Boot Mode

This feature configures the behavior of the module when the standby power supply and main power supply are ramped up.

Byte#	0	1	2	3	4	5
Content	GnS	Tgt	0x01	0x07	0x00	Boot_Mode

GnS: 0 = Set
1 = Get

Tgt 0 = RAM
1 = Flash

Boot_Mode [1..0]: 0x0 = Automatic Boot Mode detection (factory default).
The module goes into standby (S5) if the standby power supply is available before the main supply and waits for the power button. If the main power supply ramps up without the standby supply being available, the module boots up without waiting for the power button.
0x1 = The module waits in S5 state for the power button when the power supplies ramp up.
0x2 = System boots if the standby power supply or the main power supply are ramped up without waiting for the power button.

Boot_Mode [2]: 0x0 = No reboot after power fail (factory default).
0x1 = Reboots 10 seconds after a power fail

Boot_Mode [3]: 0x0 = No reboot after an over temperature event (factory default).
0x1 = Reboots 1 minute after an over temperature event

Boot_Mode [4]: 0x0 = Disable the main power boost converter (main power 7 - 14V)
Shut down and reboot the system after a change of this setting
0x1 = Enables the main power boost converter (factory default, main power 5 - 14V).
Shut down and reboot the system after changing this setting

Boot_Mode [7..5]: Must be set to 0

6.5.2 S3 Signalization Mode

This feature configures the behavior of SUS_S3# together with SUS_S5# (see chapter 5.1 for more information).

Byte#	0	1	2	3	4	5
Content	GnS	Tgt	0x01	0x04	0x00	S3_Sig

GnS: 0 = Set
1 = Get

Tgt: 0 = RAM
 1 = Flash

S3_Sig 0 = SUS_S3# signal is independent of SUS_S5# signal and is low if the system is in S3 state or S4/S5 (factory default).
 1 = SUS_S3# signal is a copy of the SUS_S5# signal. It is low only in the S4/S5 state of the system

6.5.3 Reset THRM Pin

This feature report command resets the state of the thermal shut down pin on the COM Express™ connector.

Byte#	0	1	2	3	4
Content	0x00	0x80	0x00	0x00	0x00

6.6. Toradex Z5xx Tweaker Tool

The Toradex Z5xx Tweaker Tool is a powerful tool for configuring the settings of the embedded controller. The program is divided into 4 sections: GPIO, Watchdog, Power Management and Miscellaneous. The current settings of the embedded controller are read when the tool is invoked. Changes to setting that are made in the program are written directly to the embedded controller volatile memory (RAM). Changes can be made persistent using the save-to-flash-button available for each section.



In addition to the feature report settings described in section 6.3, the Tweaker Tool allows the embedded controller serial number to be changed. The serial number can be changed according to user requirements - this serial number is not used by Toradex for module identification or traceability purposes.

7. Watchdog

The watchdog is implemented in the embedded controller on the Robin module. It is designed to enable the system to respond to and recover from unexpected events which cause the operating system or application software to hang up or stop responding. The watchdog can either restart the system or signal to the carrier board that a watchdog event has occurred. The configuration of the watchdog is described in section 6.4. The following figure provides a functional description of the watchdog in the form of a Mealy Finite State Machine (FSM).

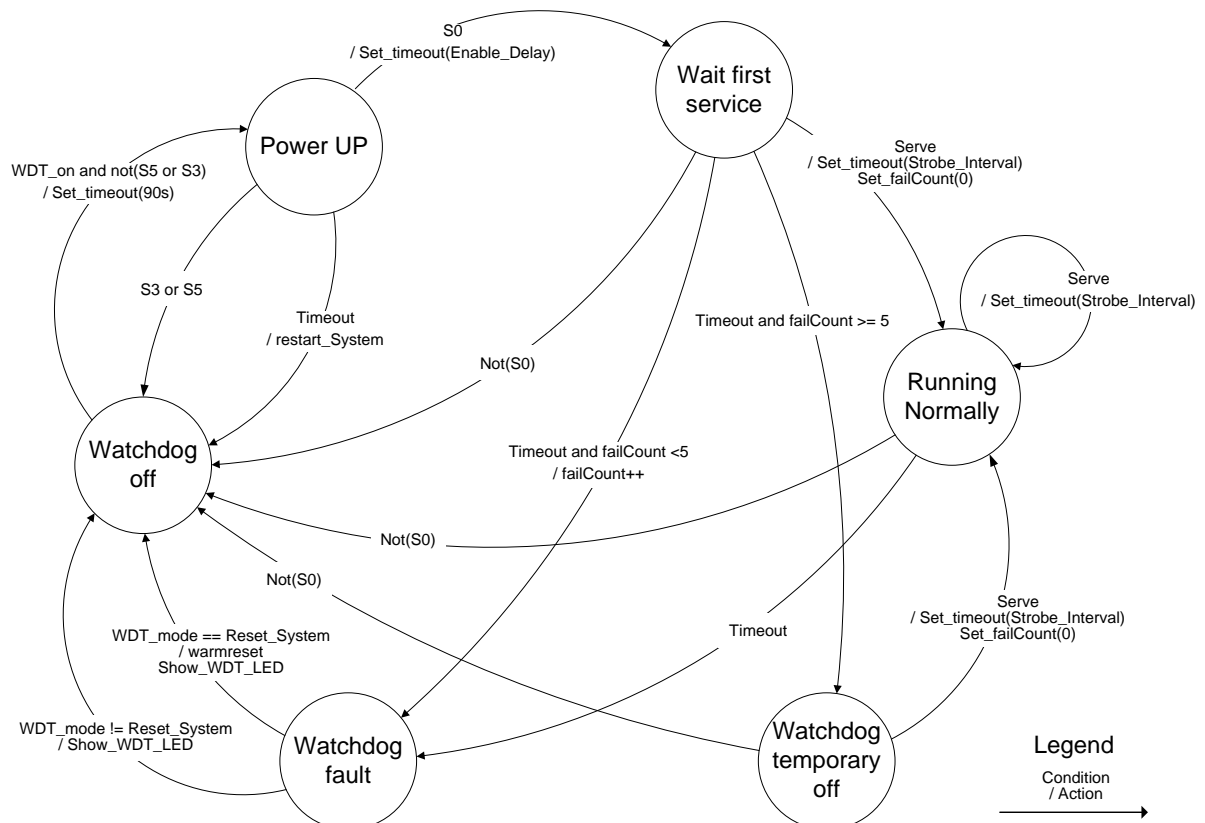

- **Watchdog off:** If the system is in the S5, S4 or S3 state, the watchdog is in this state. The FSM is also in this state if the watchdog is disabled.
- **Power UP:** This state checks for malfunctions in the power up sequence. If the power up to S0 exceeds 90 seconds, the watchdog initializes a restart of the power up sequence. Important: this function only monitors the hanging up of the power up sequence. If a power supply that was ramping up correctly fails later on in the sequence, the watchdog will not restart the system. If the system needs to restart after such a power failure has occurred, the boot mode must be set to reboot (see section 6.5.1)
- **Wait first service:** After the correct power up sequence, the watchdog waits in this state for a period of time equal to the watchdog enable delay (see section 6.4.3). This initial delay allows extra time for the operating system and the application to start. As soon as the watchdog is serviced for the first time, the watchdog transitions to the normal running state. If a timeout occurs before the watchdog is initially serviced, the watchdog transitions to fault state. If the watchdog transitions from the “Wait first service” state into the “Watchdog fault” state more than 5 times without being serviced, then it will transition to the “Watchdog temporary off” state.
- **Running Normally:** The system is in the normal running state. If the watchdog is not serviced within the strobe interval time, the watchdog transitions into the fault state.

- **Watchdog temporary off:** If the watchdog is in this state, then the watchdog was not serviced for 5 consecutive times prior to the enable delay timeout expiring. This could be due to the enable delay time being set too short or the system takes a longer time to boot than the time that has been allowed. This watchdog state allows such configuration issues to be resolved.
- **Watchdog fault:** Depending on the watchdog mode, the system may be reset on the exit transition from this state. Irrespective of the watchdog mode, the WDT signal (COM Express Connector Pin B27) will be asserted on entry to this state. This signals the watchdog event to the carrier board. The WDT signal must be reset using a USB feature report.

8. Thermal considerations

Thermal management is an important part of a Design with a Robin Z5xx module. Designers must analyze the application and design an appropriate thermal solution. Toradex provides heatsink or heatspreader as a possible part for a final design.

8.1. Temperature Range

Description	Robin Z5xx V1.0 / V2.0			Unit
	Min	Typ	Max	
Operation Temperature ¹⁾	0		60	°C
Storage Temperature	-10		85	°C

1) Maximum temperature depends on the cooling solution.

8.2. Notes for a custom heatsink or heatspreader

- **DO NOT use electrically conductive thermal grease, paste or interface material!!!**
- Using thermal grease is not recommended
- The height of the SCH and CPU varies; the thermal solution must be adaptive to the height. See chapter: *9.3.3 Details with height information*
- Using a thermal gap pad (=TIM (thermal interface material)) instead of thermal grease is highly recommended.
- Recommended TIM:
 - TIM thickness: 1mm
 - TIM Hardness: <40 (Shore 00)
 - TIM Thermal conductivity: >5 W/(mK)
 - TIM Resistance: >10¹³ Ohm
- Recommendation for distance from nominal CPU/SCH height to Heatsink: 0.5mm if using recommended TIM (thermal interface material).
 - Distance from PCB to Heatsink for SCH: 2.4 mm
 - Distance from PCB to Heatsink for CPU: 1.9mm

8.3. Temperature sensor chip

Robin Z5xx uses a temperature sensor chip which continuously measures its own and the CPU temperature. The temperature sensor chip reads the CPU temperature by means of a diode inside the CPU.

The two temperatures measured from the sensor chip:

- CPU temperature (BIOS: <Current CPU temperature>)
- Module temperature (BIOS: <Current System temperature>)

The sensor chip has two output signals:

- Warning signal
- Critical Temperature signal

8.3.1 Warning signal

For the Warning signal, there is only one temperature limit, which applies for both, the CPU and the module. It can be seen in the BIOS under <PC Health Status>.

The Warning signal may throttle the CPU by help of the OS and the BIOS.

8.3.2 Critical Temperature signal

For the Critical signal, there is a temperature limit for each, the CPU and the Module temperature. They can be seen in the BIOS under <PC Health Status>.

8.3.3 Default BIOS values

The preconfigured BIOS values are:

Robin Version	Warning limit	Critical System Temp.	Critical CPU Temp
Robin Z5xx V1.0 a-i	70°C	77°C	89°C
Robin Z5xx V2.0 a-b	70°C	70°C	89°C

9. Technical Specification

9.1. Electrical Characteristics

Symbol	Description	Robin Z530 V1.0/2.0			Robin Z510 V1.0/2.0			Unit
		Min	Typ	Max	Min	Typ	Max	
VCC_Main	Main power supply	4.75	12.0	14.5	4.75	12.0	14.5	V
VCC_5V_SBY	Optional standby power supply	4.65	5.0	5.25	4.65	5.0	5.25	V
VCC_RTC	Optional RTC battery supply	2.0	3.0	3.6	2.0	3.0	3.6	V
IFFC_3V3	Total current on FFC 3.3V out (pins 8+19)			0.5			0.5	A

9.2. Power Consumption

Test conditions:

- 1) DOS command prompt, USB Keyboard & Mouse, no network connection, VGA display (1280x1024), thermal solution applied.
- 2) Windows XP Embedded, USB Keyboard & Mouse, USB boot stick, SATA drive, MicroSD card, no network connection, VGA display (1280x1024), thermal solution applied.
- 3) Windows XP Embedded with benchmark application, USB Keyboard & Mouse, 100% CPU load, USB boot stick, SATA drive (active), SD card (active), GLAN (active), VGA display (1280x1024), and thermal solution applied.

Mode	Module										
	Main [V]	Standby [V]	Robin Z510 V1.0			Robin Z530 V1.0			Robin Z530 V2.0		
			Main [mA]	SBY [mA]	Total [W]	Main [mA]	SBY [mA]	Total [W]	Main [mA]	SBY [mA]	Total [W]
DOS prompt ¹⁾	12	5	380	9	4.6	420	9	5.1	420	9	5.1
XP Idle ²⁾	12	5	370	9	4.5	390	9	4.7	390	9	4.7
XP FullLoad ³⁾	12	5	490	9	5.9	570	9	6.9	570	9	6.9
S3 ²⁾	12	5	26	13	0.38	26	13	0.38	26	13	0.38
S5	12	5	2.4	0	0.029	2.4	0	0.029	2.4	0	0.029
	5	5	2.4	0	0.012	2.4	0	0.012	2.4	0	0.012
	NA	5	0	2.4	0.012	0	2.4	0.012	0	2.4	0.012

Specific Power consumptions

- Current on Standby Input on a running module: 9mA
- Power due to connected, but idle GLAN 432mW
- Power due to connected, but idle 100MBit LAN 144mW

9.3. Mechanical characteristics

General characteristics:

- The four mounting holes have a diameter of 2.7mm.
- The PCB thickness is
 - Robin V1.0: 1.6mm.
 - Robin V2.0: 2.0mm
- Toradex provides a heatspreader solution.

9.3.1 Mechanical characteristics of Robin Z5xx V1.0

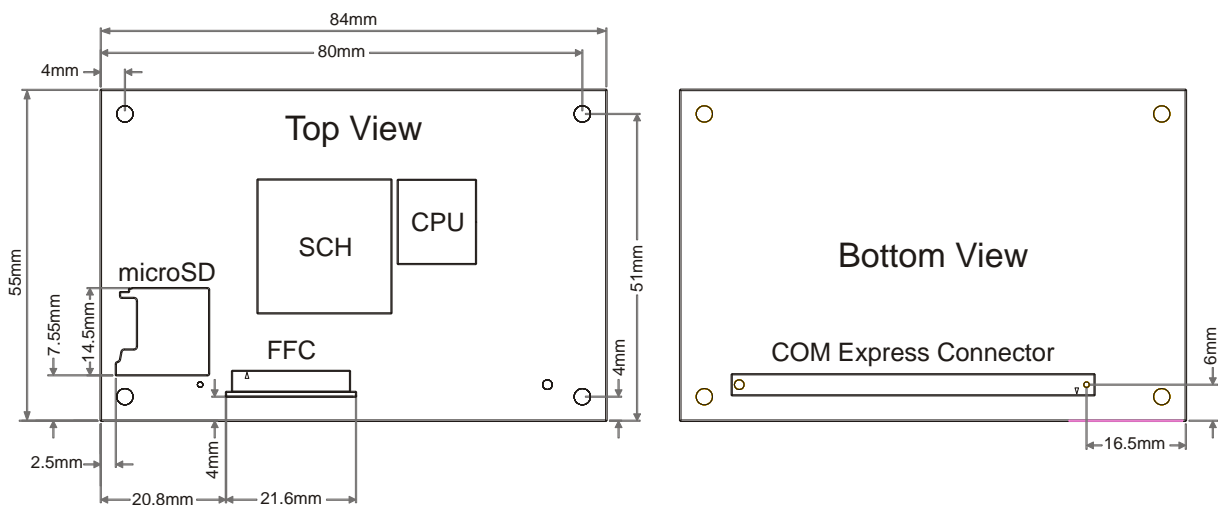

9.3.2 Mechanical characteristics of Robin Z5xx V2.0

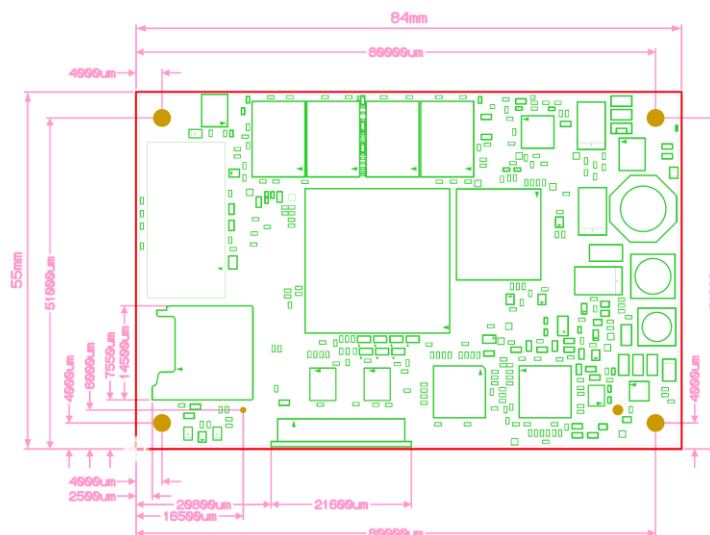

9.3.3 Details with height information

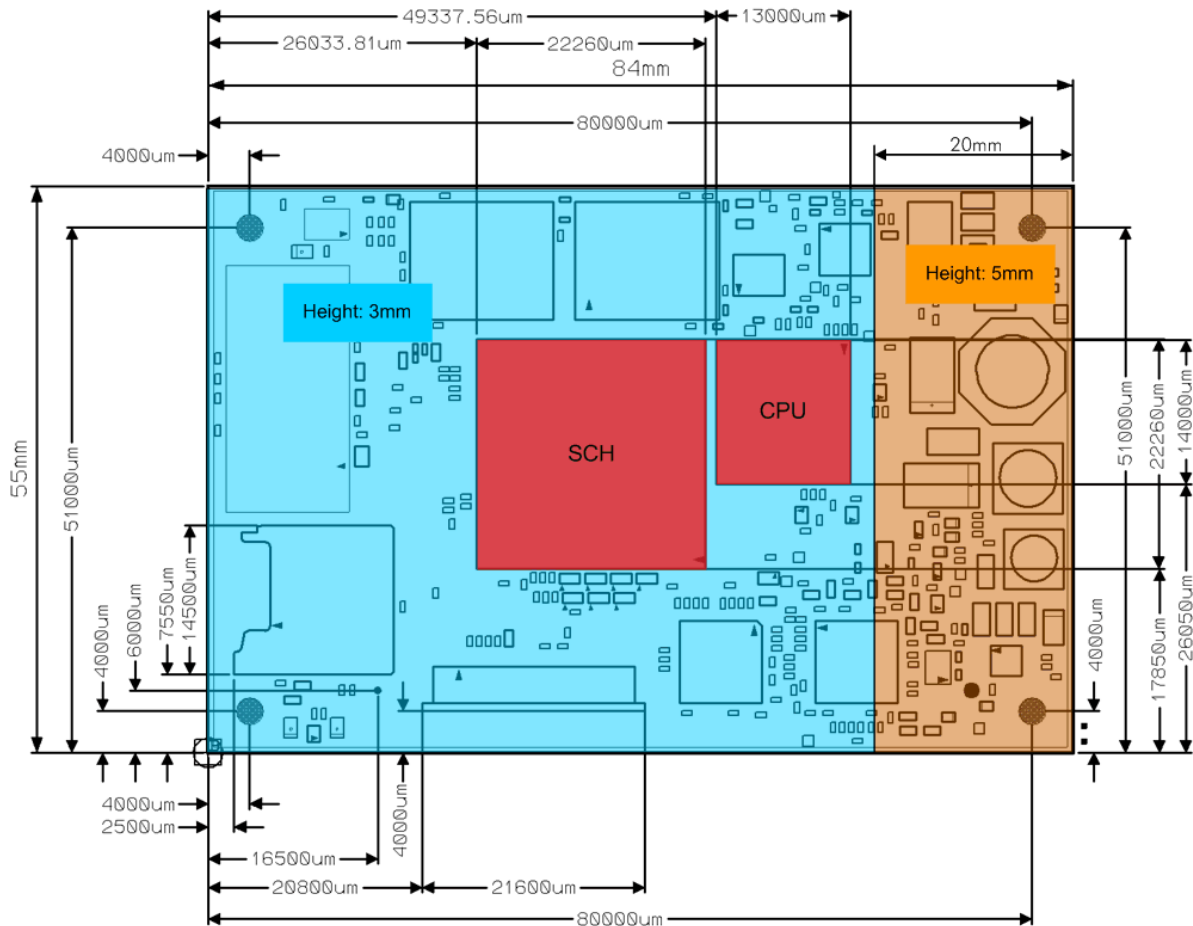

Note: Robin Z5xx V1.0 is shown, but the same guidelines for height apply to the Robin Z5xx V2.0.

- Height of the SCH: 1.875+/-0.185mm
- Height of the CPU: 1.427+/-0.110mm
- Maximum component height of blue zone (top side): 3mm
- Maximum component height of brown zone (top side): 5mm
- Maximum component height of the whole module (bottom side): 3.8mm
 - Maximum component height on carrier board under module (5mm stack option): 1mm
 - Maximum component height on carrier board under module (8mm stack option): 4mm

9.4. RoHS Compliance

The Robin Z530 and Z510 modules comply with the European Union's Directive 2002/95/EC: "Restrictions of Hazardous Substances"

Disclaimer:

Copyright © Toradex AG. All rights reserved. All data is for information purposes only and not guaranteed for legal purposes. Information has been carefully checked and is believed to be accurate; however, no responsibility is assumed for inaccuracies. Brand and product names are trademarks or registered trademarks of their respective owners. Specifications are subject to change without notice.

Trademark Acknowledgement:

Brand and product names are trademarks or registered trademarks of their respective owners.