

# Orchid V1.0

## Datasheet

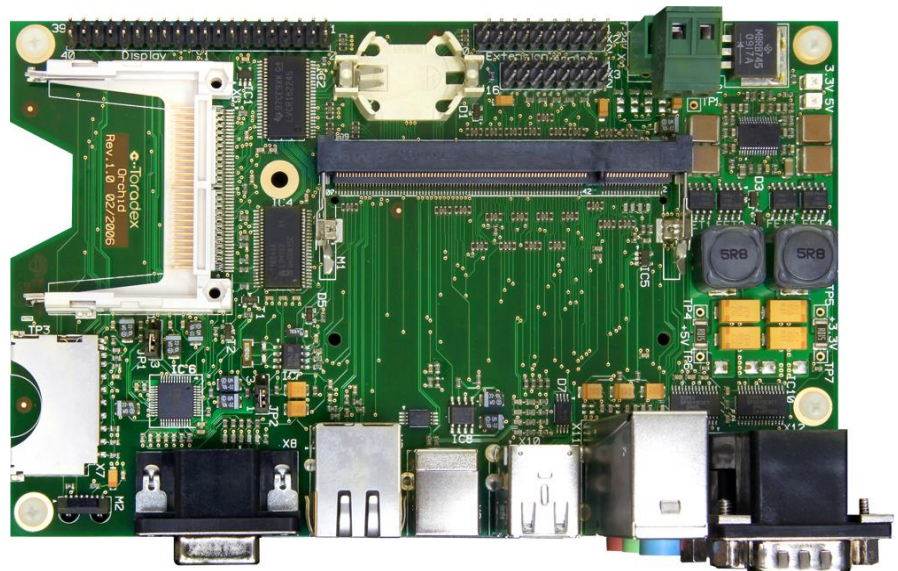

## Revision History

Date	Doc. Rev.	Orchid Version	Changes
02-May-06	Rev. 1.0	V1.00	Initial release
27-Jul-06	Rev. 1.1	V1.00	Added I2C pull-ups on User Extension connector Clarified available interfaces in standard version Corrected reference for power connector
12-Jan-07	Rev. 1.2	V1.00	Improved Mechanical Drawings
15-Oct-08	Rev. 1.3	V1.00	JP2 description updated
16-Nov-09	Rev. 1.4	V1.00	Added temperature range.
05-Jan-10	Rev. 1.5	V1.00	Correct L_BIAS IO Type Add link to Wiki
23-Nov-11	Rev. 1.6	V1.00	Changed Disclaimer Clarified PWM usage with different Colibris
08-Jan-13	Rev. 1.7	V1.00	Updated links to reference documents
31-Jan-17	Rev. 1.8	V1.00	Updated links to reference documents

## Contents

---

<b>1. Introduction</b> .....	<b>5</b>
<b>2. Features</b> .....	<b>5</b>
2.1. <i>User Interface</i> .....	5
2.2. <i>Communication</i> .....	6
2.3. <i>Extensions</i> .....	6
<b>3. Technical Specifications</b> .....	<b>6</b>
3.1. <i>Input Voltage</i> .....	6
3.2. <i>Typical Power Consumption</i> .....	6
3.3. <i>Temperature Range</i> .....	6
3.4. <i>5V / 3.3V Power Capability for User Extensions</i> .....	6
<b>4. Reference Documents</b> .....	<b>7</b>
4.1. <i>Colibri</i> .....	7
4.2. <i>PXA270</i> .....	7
4.3. <i>Toradex Developer Center</i> .....	7
<b>5. Installation</b> .....	<b>7</b>
<b>6. Orchid Connectors</b> .....	<b>8</b>
6.1. <i>Connector Locations</i> .....	8
6.1.1 <i>Connector, Jumper and Test Point list</i> .....	9
6.2. <i>SODIMM 200 Socket for Colibri Module</i> .....	9
6.3. <i>Display</i> .....	10
6.3.1 <i>Generic Display (X1)</i> .....	10
6.3.2 <i>VGA (X8)</i> .....	11
6.4. <i>Audio</i> .....	12
6.4.1 <i>3xAudio Jack (X11)</i> .....	12
6.4.2 <i>Jack Stack up</i> .....	12
6.5. <i>USB</i> .....	12
6.5.1 <i>2xUSB Host (X10)</i> .....	12
6.5.2 <i>USB Client (X9)</i> .....	13
6.6. <i>RS232, IrDA</i> .....	13
6.6.1 <i>1x (2x) RS232 (X12)</i> .....	13
6.6.2 <i>IrDA (M2)</i> .....	13
6.7. <i>Ethernet</i> .....	14
<i>Ethernet (M3)</i> .....	14
6.8. <i>Card slots</i> .....	15
6.8.1 <i>SD Card / MMC (X7)</i> .....	15
6.8.2 <i>CompactFlash (X6)</i> .....	15
6.9. <i>User Extension</i> .....	17
6.9.1 <i>User Extension (X2)</i> .....	17
6.10. <i>Analog and PWM Connector</i> .....	17

6.10.1	Analog and PWM (X3).....	17
<b>7.</b>	<b>Orchid Board Physical Drawings .....</b>	<b>19</b>
7.1.	<i>Mechanical Drawing .....</i>	<i>19</i>

## 1. Introduction

Orchid is a computer carrier board that turns the Toradex Colibri module into a ready-to-use computer. Orchid provides almost any functionality of a regular industrial PC, but at much lower power consumption.

The recommended operating system for the use with Orchid / Colibri is Windows CE. Linux and QNX are also available from third parties.

## 2. Features

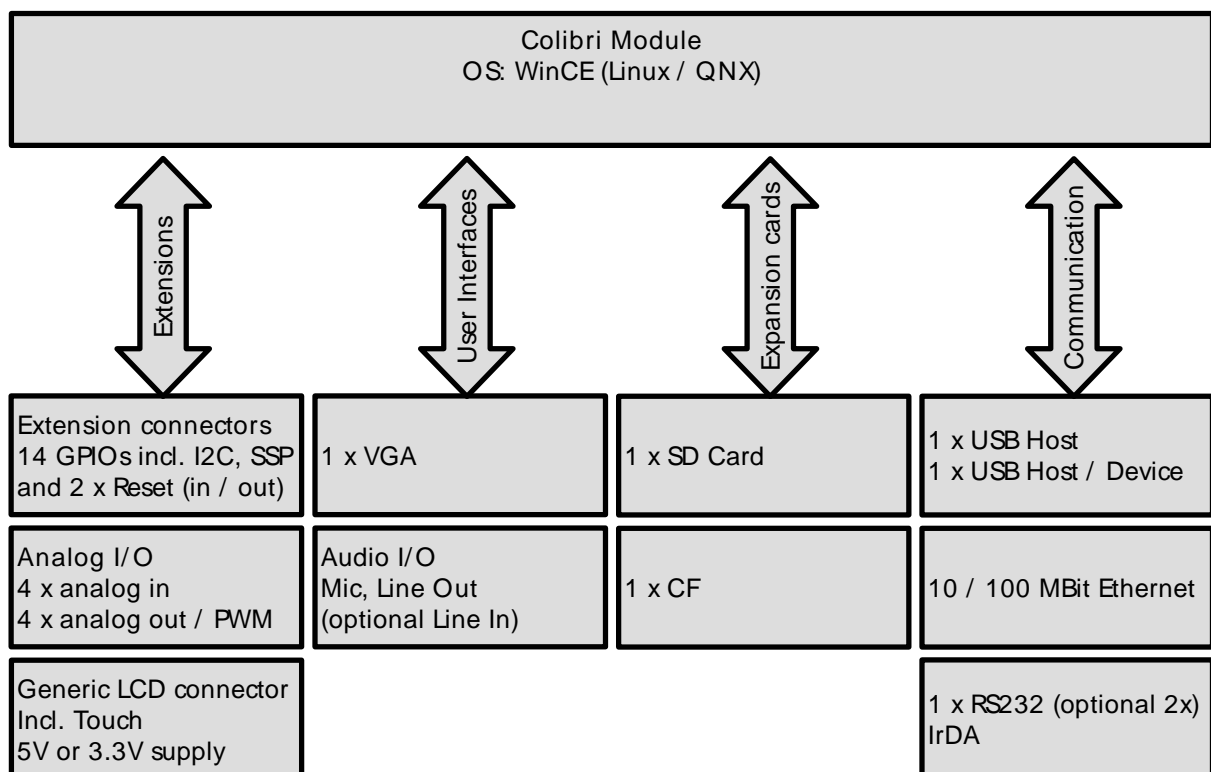

**Figure 1: Orchid Block Diagram**

### 2.1. User Interface

The following user interfaces are available on the Orchid board

VGA	maximum resolution 1024x768 262'144 colors (18 bit)
Generic LCD	2.54mm pin header interfacing to almost any available active or passive LCD panel
Touch Screen	4-wire resistive touch screen interface
Keyboard, Mouse	USB interface
Audio	Line Out (stereo) and Microphone In (mono) on standard 3.5mm jacks (optional: additional Line In)

## 2.2. Communication

Orchid provides the following communication interfaces

Ethernet	10/100Mb
USB	1 x Host 1 x Host / Device
Serial	1 x (optional 2x) RS232 maximum data rate: 921'600 bps
IrDA	Standard Infrared interface maximum data rate: 115'200 bps
Wireless LAN	ask Toradex for supported WLAN products for Compact Flash, SD card and USB

## 2.3. Extensions

Compact Flash	1 slot
SD / MMC	1 slot

## 3. Technical Specifications

---

### 3.1. Input Voltage

Input Voltage	7-24VDC Protected against reverse polarity
---------------	---

### 3.2. Typical Power Consumption

Power consumptions are measured without any peripherals connected.

Orchid including Colibri PXA270/520 MHz, Playing high-end DivX movie from on-board DRAM

1.9W typical with VGA DAC active

1.6W typical without VGA DAC (playback on TFT panel)

b) Sleep Mode

300mW typical

### 3.3. Temperature Range

Storage temperature:	-30°C to +85°C	IrDA module is limiting device
	-55°C to +125°C	For all other components (excepting IrDA)
Operating temperature:	-30°C to +85°C	

### 3.4. 5V / 3.3V Power Capability for User Extensions

The on-board power supply is capable of providing the following power:

5V / 5A	(25W)
3.3V / 5A	(16.5W)

The supply is protected against reverse input voltage polarity and short circuits, limiting the maximum current to about 5A. However the protection diode in the input voltage path is thermally not designed to carry that high current, especially at low input voltages. If your application dissipates more than 20W, please consider one of the following:

- Work with a high input voltage, close to 24V

- Add a heat sink to the polarity protection diode
- Short the polarity protection diode D2 with a wire (this removes the reverse polarity protection!)

## 4. Reference Documents

---

### 4.1. Colibri

- Intel PXA270 based Single Board Computer Colibri Datasheet:  
<https://www.toradex.com/computer-on-modules/colibri-arm-family/intel-marvell-xscale-pxa270>

### 4.2. PXA270

- Intel® PXA270 Processor Electrical, Mechanical and Thermal Specification Datasheet:  
[www.intel.com/design/pca/applicationsprocessors/datashts/280002.htm](http://www.intel.com/design/pca/applicationsprocessors/datashts/280002.htm)
- Intel® PXA27x Processor Family Design Guide:  
[www.intel.com/design/pca/applicationsprocessors/manuals/280001.htm](http://www.intel.com/design/pca/applicationsprocessors/manuals/280001.htm)
- Intel® PXA27x Processor Family Developers Manual:  
[www.intel.com/design/pca/applicationsprocessors/manuals/280000.htm](http://www.intel.com/design/pca/applicationsprocessors/manuals/280000.htm)

### 4.3. Toradex Developer Center

- Toradex Developer Center  
<http://developer.toradex.com>

## 5. Installation

---

Follow these steps for a quick start with the Orchid:

1. If not already done, insert a Colibri Module in the SODIMM socket M1 on the Orchid
2. Connect a VGA monitor to the corresponding connector X8 and a mouse to the upper USB port.
3. Connect an external power supply to X5 (green connector)(7-24V, 3W min, depending on your peripherals)
4. Turn on the external power supply

Now the preinstalled operating system will boot.

For a detailed documentation of the Windows CE software as well as for the latest bootloader and software images please refer to the Colibri Web site at [www.toradex.com](http://www.toradex.com).

## 6. Orchid Connectors

### 6.1. Connector Locations

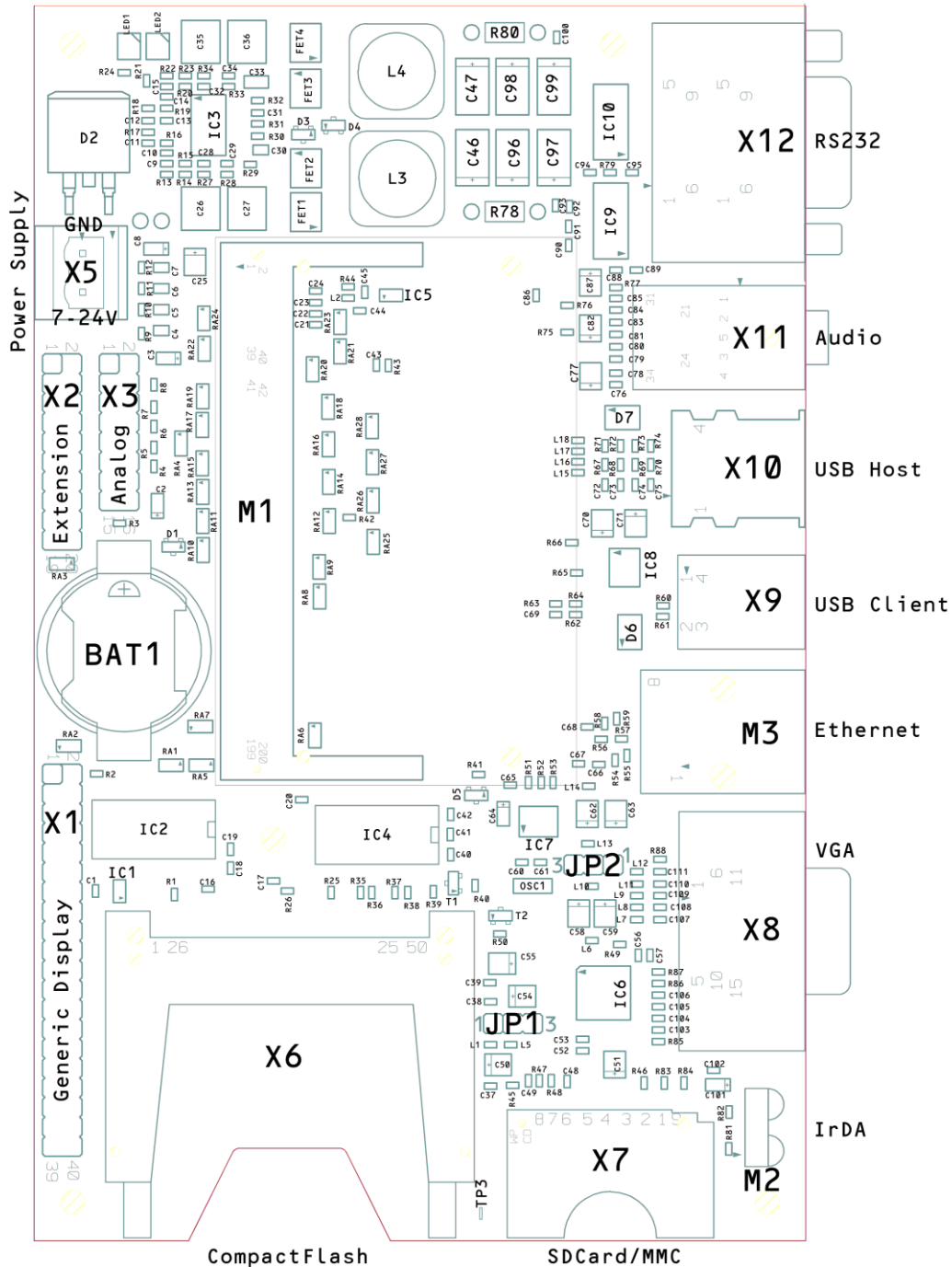

**Figure 2: Orchid Layout: Top View**



### 6.1.1 Connector, Jumper and Test Point list

Reference Designator	Name
X1	Generic Display and Touch-Screen
X2	User Extension
X3	Analog In and PWM out
X5	Power Supply (7-24V DC)
X6	CompactFlash
X7	SDCard/MMC
X8	VGA
X9	USB Client (shared)
X10	2x USB Host (bottom: shared)
X11	3x Audio Jack
X12	2x RS232
M1	SODIMM 200 Socket for Colibri Module
M2	IrDA
M3	Ethernet
JP1	5V / 3.3V selection for Generic Display Jumper Position 1-2 = 5V Jumper Position 2-3 = 3.3V (default)
JP2	Ethernet controller selection Jumper Position 1-2 (default) Use for: Colibri PXA270  Jumper Position 2-3 Use for: Colibri PXA320 / 310 / 300
TP1	BATT_FAULT (SODIMM Pin 24)
TP2	VDD_FAULT (SODIMM Pin 22)
TP3	SD Card Write Protect
TP5 / TP7	For measurement of +3V3 supply
TP4 / TP6	For measurement of +5V supply

### 6.2. SODIMM 200 Socket for Colibri Module

Orchid's core is the Toradex Colibri Module, seated in a standard SODIMM 200 socket. Mounting holes are provided that allow fixing the module to the Orchid carrier board for the use in harsh environments.

For details about the module and provided software, please refer to the latest Colibri Module documentation.

### 6.3. Display

Almost any TFT or STN display can be connected to the Orchid's LCD port. A simple wiring adapter is usually needed to interface between Orchid's generic 2.54mm pin header and the proprietary display connector.

Display parameters can be set on the fly using WinCE utilities which Toradex has already included in the BSP.

#### 6.3.1 Generic Display (X1)

Part number: 2x20Pin Header Male, 2.54mm

Pin Nr.	Signal Name	Description (6r6g6b TFT) <sup>2</sup>	IO Type	Voltage	Pullup/Pulldown
1	GND	Signal Ground	PWR		
2	L_PCLK	Pixel clock	OI	+3V3	
3	L_LCLK	Horizontal Sync Signal	O	+3V3	
4	L_FCLK	Vertical Sync Signal	O	+3V3	
5	GND	Signal Ground	PWR		
6	LDD[12]	Red Data 0[LSB]	O	+3V3	
7	LDD[13]	Red Data 1	O	+3V3	
8	LDD[14]	Red Data 2	O	+3V3	
9	LDD[15]	Red Data 3	O	+3V3	
10	LDD[16]	Red Data 4	O	+3V3	
11	LDD[17]	Red Data 5[MSB]	O	+3V3	
12	GND	Signal Ground	PWR		
13	LDD[6]	Green Data 0[LSB]	O	+3V3	
14	LDD[7]	Green Data 1	O	+3V3	
15	LDD[8]	Green Data 2	O	+3V3	
16	LDD[9]	Green Data 3	O	+3V3	
17	LDD[10]	Green Data 4	O	+3V3	
18	LDD[11]	Green Data 5[MSB]	O	+3V3	
19	GND	Signal Ground	PWR		
20	LDD[0]	Blue Data 0[LSB]	O	+3V3	
21	LDD[1]	Blue Data 1	O	+3V3	
22	LDD[2]	Blue Data 2	O	+3V3	
23	LDD[3]	Blue Data 3	O	+3V3	
24	LDD[4]	Blue Data 4	O	+3V3	
25	LDD[5]	Blue Data 5[MSB]	O	+3V3	
26	GND	Signal Ground	PWR		
27	L_BIAS	Data Enable	O	+3V3	
28	+V_DISPLAY	Supply voltage for display driver	PWR		JP1 selects +3V3/+5V
29	+V_DISPLAY	Supply voltage for display driver	PWR		JP1 selects +3V3/+5V
30	GND	Ground	PWR		
31	GND	Ground	PWR		
32	GND	Ground	PWR		
33	TSMY	Touch screen	IO		

Pin Nr.	Signal Name	Description (6r6g6b TFT) <sup>2</sup>	IO Type	Voltage	Pullup/Pulldown
34	TSMX	Touch screen	IO		
35	TSPY	Touch screen	IO		
36	TSPX	Touch screen	IO		
37	BL_ON	Back light on signal	O	+3V3	
38	BL_GND	Back light ground	PWR		
39	BL_+5V	Back light supply voltage	PWR	+5V	
40	BL_GND	Back light ground	PWR		

Note 2: The signal description relates to the case where a TFT Display with 6 Bit per color is used. The Colibri module supports further display modes where the signals may have different functions. The most common modes can be set using the Colibri Tweak Tool form Toradex. Please refer to *Intel® PXA27x Processor Family Developer's Manual* chapter 7 to get more information about alternative display modes and the corresponding signal descriptions.

### 6.3.2 VGA (X8)

Type: High Density DSUB15

Pin Nr.	Signal Name
1	VGA_RED
2	VGA_GREEN
3	VGA_BLUE
4	NC
5	VGA_AGND
6	VGA_AGND
7	VGA_AGND
8	VGA_AGND
9	VGA_AGND
10	VGA_AGND
11	NC
12	NC
13	L_LCLK
14	L_FCLK
15	NC

## 6.4. Audio

The stacked connector offers standard 3.5mm stereo jacks for active loudspeakers or headphones, for line-in and microphone input.

### 6.4.1 3xAudio Jack (X11)

Type: 2x (3x) 3.5mm Jack stacked

Pin Nr.	Signal Name	IO Type	Voltage	Pullup/Pulldown
1	MIC_AVCC	Not connected		
2	MIC_AVCC	Not connected		
3	MIC_IN	I		
4	MIC_IN	I		
5	AUDIO_AGND	PWR		
21	HEADPHONE_R	O		
22	HEADPHONE_R	O		
23	HEADPHONE_L	O		
24	HEADPHONE_L	O		
31 <sup>1</sup>	LINEIN_R <sup>1</sup>	I		
32 <sup>1</sup>	LINEIN_R <sup>1</sup>	I		
33 <sup>1</sup>	LINEIN_L <sup>1</sup>	I		
34 <sup>1</sup>	LINEIN_L <sup>1</sup>	I		

Note 1: In the standard version of Orchid, these signals are not available

### 6.4.2 Jack Stack up

Position	Jack Name	IO Type
Top <sup>1</sup>	LINE IN <sup>1</sup>	I
Middle	LINE OUT	O
Bottom	MIC IN	I

Note 1: In the standard version of Orchid, this interface is not available

## 6.5. USB

The Orchid offers 2 USB channels. One dedicated USB Host and a shared USB Host / Client. Only one of the shared ports either the USB Client or the bottom USB Host may be used at the same time.

### 6.5.1 2xUSB Host (X10)

Type: 2 x USB-Host stacked  
(Ax = Upper, Bx = Lower Connector; Lower Connector is shared with USB Client)

Pin Nr.	Signal Name
A1	USBH1_AVCC
A2	USBH1_N
A3	USBH1_P
A4	GND
B1	USBH2_AVCC
B2	USBH2_N
B3	USBH2_P
B4	GND

### 6.5.2 USB Client (X9)

Type: USB Client

Pin Nr.	Signal Name
1	USBC_AVCC
2	USBC_N
3	USBC_P
4	GND

## 6.6. RS232, IrDA

### 6.6.1 1x (2x) RS232 (X12)

Type: 1x (2x) DSUB9 Male stacked (Ax = Upper<sup>1</sup>, Bx = Lower Connector)

Pin Nr.	Signal Name
A1 <sup>1</sup>	NC <sup>1</sup>
A2 <sup>1</sup>	UART_BT_U_RXD <sup>1</sup>
A3 <sup>1</sup>	UART_BT_U_TXD <sup>1</sup>
A4 <sup>1</sup>	UART_BT_U_DTR (always high) <sup>1</sup>
A5 <sup>1</sup>	GND <sup>1</sup>
A6 <sup>1</sup>	NC <sup>1</sup>
A7 <sup>1</sup>	UART_BT_U_RTS <sup>1</sup>
A8 <sup>1</sup>	UART_BT_U_CTS <sup>1</sup>
A9 <sup>1</sup>	NC <sup>1</sup>
B1	UART_FF_L_DCD
B2	UART_FF_L_RXD
B3	UART_FF_L_TXD
B4	UART_FF_L_DTR
B5	GND
B6	UART_FF_L_DSR
B7	UART_FF_L_RTS
B8	UART_FF_L_CTS
B9	UART_FF_L_RI

Note 1: In the standard version of Orchid, these signals are not available

### 6.6.2 IrDA (M2)

Pin Nr.	Signal Name
1	+3V3
2	NC
3	IrDA_TXD
4	IrDA_RXD
5	NC
6	+3V3
7	NC
8	GND

## 6.7. Ethernet

Orchid offers an RJ45 connector with integrated magnetic for 10/100Mbps Ethernet. With Jumper JP2 two different Ethernet controller settings can be configured:

JP2	Comment
1 - 2	Colibri PXA270 revisions (default)
2 - 3	Colibri PXA320 / 310 / 300 and future successors

In case of wrong Jumper setting no damage will occur but Ethernet connection will fail.

### Ethernet (M3)

Type: RJ-45

Pin Nr.	Signal Name	IO Type	Voltage	Pullup/Pulldown
1	TXO+	O	+3V3	If JP2(1-2)50R to ETH_AVCC
2	TXO-	O	+3V3	If JP2(1-2) 50R to ETH_AVCC
3	ETH_AVCC	PWR		
4	NC	Not connected		
5	NC	Not connected		
6	If Jumper2(1-2):ETH_AGND; If Jumper2(2-3):ETH_AVCC	PWR		
7	RXI+	I	+3V3	
8	RXI-	I	+3V3	
9	+3V3	PWR		
10	LINK_AKT	I	+3V3	
11	SPEED100	I	+3V3	
12	+3V3	PWR		
13	SHIELD			
14	SHIELD			

## 6.8. Card slots

The hardware supported card detect function is implemented, but not the write protect feature.

### 6.8.1 SD Card / MMC (X7)

Type: SDIO-Socket

Pin Nr.	Signal Name	IO Type	Voltage	Pullup/Pulldown
1	MMDAT[3]	IO	+3V3	68k to +3V3
2	MMCMD	I	+3V3	33k to +3V3
3	GND	PWR		
4	+3V3	PWR		
5	MMCLK	I	+3V3	
6	GND	PWR		
7	MMDAT[0]	IO	+3V3	68k to +3V3
8	MMDAT[1]	IO	+3V3	68k to +3V3
9	MMDAT[[2]	IO	+3V3	68k to +3V3

### 6.8.2 CompactFlash (X6)

Type: CF-Socket

Pin Nr.	Signal Name	IO Type	Voltage	Pullup/Pulldown
1	GND	PWR		
2	CF_D[3]	IO	+3V3	
3	CF_D[4]	IO	+3V3	
4	CF_D[5]	IO	+3V3	
5	CF_D[6]	IO	+3V3	
6	CF_D[7]	IO	+3V3	
7	PCE1	O	+3V3	
8	CF_A[10]	O	+3V3	
9	POE	O	+3V3	
10	CF_A[9]	O	+3V3	
11	CF_A[8]	O	+3V3	
12	CF_A[7]	O	+3V3	
13	+3V3S	PWR		
14	CF_A[6]	O	+3V3	
15	CF_A[5]	O	+3V3	
16	CF_A[4]	O	+3V3	
17	CF_A[3]	O	+3V3	
18	CF_A[2]	O	+3V3	
19	CF_A[1]	O	+3V3	
20	CF_A[0]	O	+3V3	
21	CF_D[0]	IO	+3V3	
22	CF_D[1]	IO	+3V3	
23	CF_D[2]	IO	+3V3	
24	PIOIS16	I	+3V3	100k to +3V3

Pin Nr.	Signal Name	IO Type	Voltage	Pullup/Pulldown
25	CD1	I	+3V3	100k to +3V3
26	CD2	I	+3V3	100k to +3V3
27	CF_D[11]	IO	+3V3	
28	DF_D[12]	IO	+3V3	
29	CF_D[13]	IO	+3V3	
30	CF_D[14]	IO	+3V3	
31	CF_D[15]	IO	+3V3	
32	PCE2	I	+3V3	
33	NC	Not connected		
34	PIOR	O	+3V3	
35	PIOW	O	+3V3	
36	CF_WE	O	+3V3	
37	PRDY	I	+3V3	100k to +3V3
38	+3V3S	PWR		
39	NC	Not connected		
40	NC	Not connected		
41	PRST	O	+3V3	
42	PWAIT	I	+3V3	100k to +3V3
43	NC	Not connected		
44	PREG	O	+3V3	
45	PBVD2	I	+3V3	100k to +3V3
46	PBVD1	I	+3V3	100k to +3V3
47	CF_D[8]	IO	+3V3	
48	CF_D[9]	IO	+3V3	
49	CF_D[10]	IO	+3V3	
50	GND	PWR		



## 6.9. User Extension

The User extension connector provides several GPIO's and some Power and Reset pins.

### 6.9.1 User Extension (X2)

Type: 2x10Pin Header Male, 2.54mm

Pin Nr.	Colibri SODIMM PIN	Colibri PXA270 Vx.xx Signal	IO Type	Voltage	Pullup/Pulldown
1	SODIMM Pin 26	nRESET_IN	I	+3V3	Pullup
2	GND	GND	PWR		
3	SODIMM Pin 87	nRESET_OUT	O	+3V3	
4	+3V3	+3V3	PWR		
5	SODIMM Pin 194	I2C_DATA (GPIO 118)	IO	+3V3	Pullup (connected to on Board RTC)
6	SODIMM Pin 196	I2C_CLK (GPIO 117)	IO	+3V3	Pullup (connected to on Board RTC)
7	SODIMM Pin 88	SSPCLK (GPIO 23)	IO	+3V3	
8	SODIMM Pin 86	SSPFRM (GPIO 24)	IO	+3V3	
9	SODIMM Pin 92	SSPTXD (GPIO 25)	IO	+3V3	
10	SODIMM Pin 90	SSPRXD (GPIO 26)	IO	+3V3	
11	+5V	+5V	PWR		
12	SODIMM Pin 135	GPIO 35	IO	+3V3	
13	SODIMM Pin 133	GPIO 37	IO	+3V3	
14	SODIMM Pin 127	GPIO 36	IO	+3V3	
15	SODIMM Pin 107	GPIO 79	IO	+3V3	
16	SODIMM Pin 105	GPIO 15	IO	+3V3	
17	SODIMM Pin 106	GPIO 80	IO	+3V3	
18	SODIMM Pin 73	GPIO 52	IO	+3V3	Pullup (100k)
19	SODIMM Pin 55	GPIO 19	IO	+3V3	Pullup (100k)
20	GND	GND	PWR		

## 6.10. Analog and PWM Connector

The analog inputs and PWM outputs are directly connected to the accordant SODIMM pins. It's possible to convert the PWM outputs to analog outputs by simply stuffing a series resistor and a capacitor which then build a low-pass filter. See R9..R12 and C4..C7. Not all Colibri modules provide 4 PWM signals. Check Colibri Migration and Design Guide for details.

### 6.10.1 Analog and PWM (X3)

Type: 2x8Pin Header Male, 2.54mm

Pin Nr.	Colibri SODIMM PIN	Colibri PXA270 Vx.xx Signal	IO Type	Voltage	Pullup/Pulldown
1	SODIMM Pin 8	ANALOG_IN[0]	I	+3V3	
2	AGND		PWR		
3	SODIMM Pin 6	ANALOG_IN[1]	I	+3V3	
4	AGND		PWR		
5	SODIMM Pin 4	ANALOG_IN[2]	I	+3V3	
6	AGND		PWR		
7	SODIMM Pin 2	ANALOG_IN[3]	I	+3V3	
8	AGND		PWR		

Pin Nr.	Colibri SODIMM PIN	Colibri PXA270 Vx.xx Signal	IO Type	Voltage	Pullup/Pulldown
9	SODIMM Pin 30	PWM_OUT[0] (GPIO 16)	IO	+3V3	
10	GND		PWR		
11	SODIMM Pin 67	PWM_OUT[1] (GPIO 17)	IO	+3V3	
12	GND		PWR		
13	SODIMM Pin 28	PWM_OUT[2] (GPIO 11)	IO	+3V3	
14	GND		PWR		
15	SODIMM Pin 59	PWM_OUT[3] (GPIO 12)	IO	+3V3	
16	GND		PWR		

## 7. Orchid Board Physical Drawings

### 7.1. Mechanical Drawing

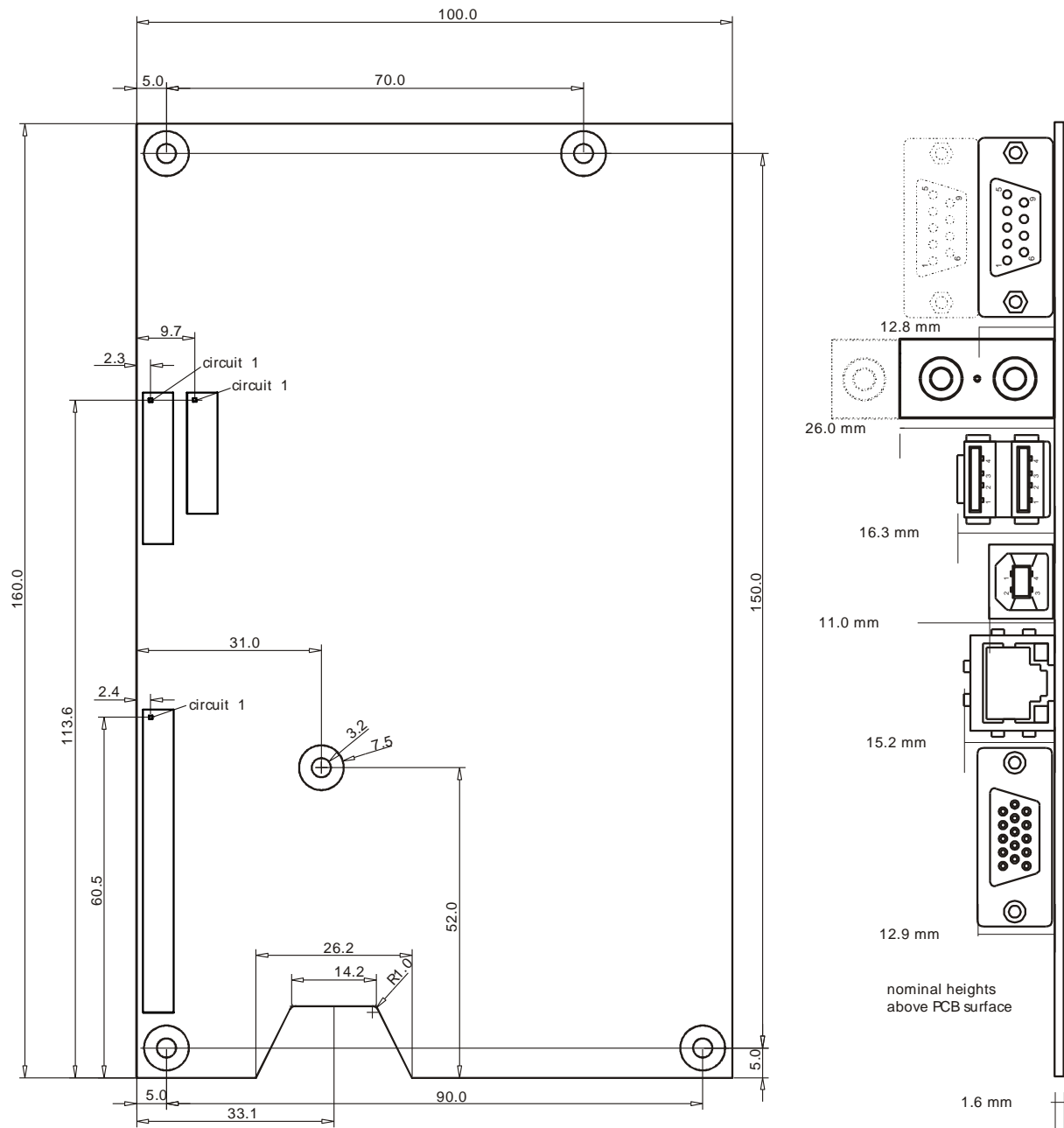

Fig. 3: Mechanical Drawing and Mounting Hole Positions

**Disclaimer:**

Copyright © Toradex AG. All rights reserved. All data is for information purposes only and not guaranteed for legal purposes. Information has been carefully checked and is believed to be accurate; however, no responsibility is assumed for inaccuracies.

Brand and product names are trademarks or registered trademarks of their respective owners.

Specifications are subject to change without notice.